

TECHNICAL MANUAL

**OPERATOR'S, ORGANIZATIONAL, DIRECT SUPPORT, AND
GENERAL SUPPORT MAINTENANCE MANUAL
(INCLUDING REPAIR PARTS AND SPECIAL TOOLS LISTS)**

FOR

**METER, AUDIO LEVEL TA-885/U
(HEWLETT-PACKARD MODEL 3555B)
(NSN 6625-00-255-1083)**

This manual contains copyrighted material reproduced by permission of Hewlett-Packard Company. All rights are reserved.

TECHNICAL MANUAL

No. 11-6625-2779-14&P

HEADQUARTERS
DEPARTMENT OF THE ARMY.
WASHINGTON, DC, 11 March 1980

**OPERATOR'S, ORGANIZATIONAL, DIRECT SUPPORT AND GENERAL
SUPPORT MAINTENANCE MANUAL (INCLUDING REPAIR PARTS AND
SPECIAL TOOLS LISTS) FOR
METER, AUDIO LEVEL TA-885/U
(HEWLETT-PACKARD MODEL 3555B)
(NSN 6625-00-255-1083)**

REPORTING ERRORS AND RECOMMENDING IMPROVEMENTS

You can help improve this manual. If you find any mistakes or if you know of a way to improve the procedures, please let us know. Mail your letter or DA Form 2028 (Recommended Changes to Publications and Blank Forms), or DA Form 2028-2 located in back of this manual direct to Commander, US Army Communications and Electronics Materiel Readiness Command, ATTN: DRSEL-ME-MQ, Fort Monmouth, NJ 07703.

In either case, a reply will be furnished direct to you.

This manual is an authentication of the manufacturer's commercial literature which, through usage, has been found to cover the data required to operate and maintain this equipment. The manual was not prepared in accordance with military specifications; therefore, the format has not been structured to consider categories of maintenance.

	Para	Page
SECTION 0. INTRODUCTION		
Scope	0-1	0-1
Indexes of Publications	0-2	0-1
Maintenance forms, records, and reports.....	0-3	0-1
Administrative storage.....	0-4	0-2
Destruction of Army electronics materiel.....	0-5	0-2
Reporting of equipment improvements recommendations (EIR).....	0-6	0-2
Items comprising an operable equipment	0-7	0-3
I. GENERAL INFORMATION		
Introduction.....	1-1	1-1
Accessory equipment supplied	1-9	1-2
Instrument identification	1-11	1-2
150 BAL modification	1-13	1-2
II. INSTALLATION		
Inspection	2-1	2-1
Warranty exception	2-3	2-1
Power requirements	2-5	2-1
Three-conductor power cable	2-7	2-1
Battery	2-10	2-1
Installation and removal of battery.....	2-12	2-2
Cover removal.....	2-15	2-2
Repackaging for shipment.....	2-17	2-2
III. OPERATING INSTRUCTIONS		
Introduction.....	3-1	3-1
Controls, connectors and indicators.....	3-4	3-1
Operation.....	3-6	3-1
Battery	3-8	3-1
Level and noise measurements	3-12	3-5
Level measurements	3-14	3-5
Noise measurements	3-28	3-7
Recorder compatibility.....	3-41	3-8
Applications	3-45	3-8
Transmission loss measurements	3-48	3-10

SECTION		Para	Page
	III. OPERATING INSTRUCTIONS (Cont.)		
	Crosstalk measurements.....	3-53	3-10
	Identifying noise characteristics.....	3-57	3-10
	Measurements in DBC.....	3-64	3-11
	Measurement procedures.....	3-67	3-12
	150 BAL conversion.....	3-69	3-12
	IV. THEORY OF OPERATION		
	Introduction.....	4-1	4-1
	Block diagram description.....	4-7	4-1
	Detailed circuit description.....	4-16	4-2
	Range attenuator A2.....	4-18	4-3
	Input amplifier A3.....	4-20	4-3
	Filters.....	4-25	4-4
	Meter amplifier.....	4-30	4-7
	Detector.....	4-32	4-7
	Power supply and series regulator.....	4-37	4-8
	V. MAINTENANCE		
	Introduction.....	5-1	5-1
	Factory selected values.....	5-4	5-1
	150 BAL conversion.....	5-6	5-1
	Performance Checks.....	5-7	5-2
	Adjustment and calibration procedure.....	5-14	5-8
	Assembly removal.....	5-25	5-10
	Troubleshooting procedures.....	5-27	5-10
	Factory selected values.....	5-39	5-15
	VI. REPLACEABLE PARTS		
	Introduction.....	6-1	6-1
	Ordering information.....	6-4	6-1
	VII. CIRCUIT DIAGRAMS		
	Introduction.....	7-1	7-1
	Functional block diagrams.....	7-3	7-1
	Schematic diagrams.....	7-5	7-1
APPENDIX	A. REFERENCES.....		A-1
APPENDIX	B. MAINTENANCE ALLOCATION		
SECTION	I. Introduction.....		B-1
	II. Maintenance allocation chart for Meter, Audio Level TA-885/U.....		B-3
	III. Tool and test equipment requirements for Meter, Audio Level TA-883/U.....		B-4
	IV. Remarks (Not applicable)		
APPENDIX	C. MANUAL BACKDATING CHANGES.....		C-1

LIST OF ILLUSTRATIONS

Number	Page	Number	Page
1-1. Model 3555B Transmission and Noise Measuring Set.....	1-1	4-7. Simplified Peak Detection.....	4-7
2-1. Power Plugs	2-1	5-1. Balanced BNC to 310 Plug	5-2
3-1. Front Panel Controls, Indicators, and Connectors	3-2	5-2. Level Accuracy Check	5-2
3-2. Side Panel Controls and Connectors.....	3-4	5-3. +20dBm and +30dBm Level Accuracy Check.....	5-4
3-3. Impedance Matching 3555B to Recorder	3-8	5-4. Return Loss Test Set-Up.....	5-5
3-4. Recorder Compatibility Chart.....	3-9	5-5. Filter Response Test Set-Up	5-5
3-5. Simplified Send/Receive Test Set-Up.....	3-9	5-6. Bridging Loss Test Set-Up	5-6
3-6. Typical Test Set-Up for Measuring Insertion Loss	3-10	5-7. Input Balance Test Set-Up.....	5-7
3-7. Test Set-Up for Measuring Crosstalk Coupling Loss	3-11	5-8. Troubleshooting Tree.....	5-11
3-8. Simple Test for Inductive and Capacitive Coupling.....	3-12	7-1. Functional Block Diagram	7-3/7-4
4-1. Simplified Block Diagram.....	4-1	7-2. A1 Function Assembly Schematic and Component Location.....	7-5/7-6
4-2. Simplified DIAL BAT Function	4-2	7-3. A2 Range Attenuator and A3 Input Amplifier Schematic and Component Location.....	7-7/7-8
4-3. Simplified NG Function.....	4-3	7-4. A4 Filter Schematic and Component Location.....	7-9/7-10
4-4. Simplified Average Detection.....	4-4	7-5. A3 Meter Amplifier, Detector and Series Regulator Schematic and Component Locations.....	7-11/7-12
4-5. 3kHz FLAT and PROGRAM Weighting Curves.....	4-5		
4-6. C-MSG and 15kHz FLAT Weighting Curves.....	4-6		

LIST OF TABLES

Number	Page	Number	Page
1-1 Specifications	1-0	5-1 Required Test Equipment	5-1
1-2 Accessory Equipment Supplied.....	1-2	5-2 75 UNBAL Carrier Accuracy Check.....	5-3
2-1 Suitable Batteries Meeting NEDA 202 Specifications.....	2-1	5-3 Carrier 600 BAL and 135 BAL Level Accuracy Check.....	5-3
3-1 Front, Side and Rear Panel Controls, Indicators and Connectors	3-3/3-5	5-4 VF/Nm Level Accuracy Checks 600 BAL and 900 BAL -80 dBm Through +30 dBm	5-4
3-2 Crosstalk Correction Factor	3-10	5-5 Filter Response Checks	5-6
3-3 Level Measurement	3-13	5-6 Front Panel Trouble Analysis	5-12/5-13
3-4 Noise Metallic Measurements	3-13	5-7 Function Troubleshooting.....	5-14
3-5 Noise-to-Ground Measurements	3-14	5-8 FUNCTION Switch Resistance Values.....	5-15
3-6 Balance Measurement	3-14	5-9 Range Attenuation and Amplifier Gain	5-16
3-7 Recorder Calibration.....	3-14	5-10 Resistance Checks	5-16
3-8 Transmission Loss Measurement.....	3-14	5-11 Factory Selected Values	5-16
4-1 Range Attenuation and Amplifier Gain	4-4	6-1 Replaceable Parts	6-2
		6-2 Part Number-National Stock Number Cross Reference Index	6-10

SECTION 0
INTRODUCTION

0-1. Scope

This manual contains instructions for the operation, organizational maintenance and general support maintenance of Audio Level Meter TA-885/U. Throughout this manual, the equipment is referred to by its commercial designation of Hewlett-Packard Model 3555B Transmission and Noise Measuring Set or simply as the 3555B. Appendix A of the manual contains a list of references and appendix B contains the maintenance allocation chart (MAC).

NOTE

No direct support maintenance functions are authorized for this equipment.

0-2. Indexes of Publications

a. DA Pam 310-4. Refer to the latest issue of DA Pam 310-4 to determine if there are any new editions, changes, or additional publications pertaining to this equipment.

b. DA Pam 310-7. Refer to DA Pam 310-7 to determine if there are any modification work orders (MWO's) pertaining to this equipment.

0-3. Maintenance Forms, Records, and Reports

a. Reports of Maintenance and Unsatisfactory Equipment. Department of the Army forms and procedures used for equipment maintenance will be those described by TM 38-750, The Army Maintenance Management System.

b. Report of Packaging and Handling Deficiencies. Fill out and forward DD Form 6 (Packaging Improvement Report) as prescribed in AR 700-58/NAVSUPINST 4030.29/AFR 71-13/MCO P4030.29A, and DLAR 4145.8.

c. Discrepancy in Shipment Report (DISREP) (SF 361). Fill out and forward Discrepancy in Shipment Report (DISREP) (SF 361) as prescribed in AR 55-38/NAVSUPINST 4610.33B/AFR 75-18 MCO P4610.19C and DLAR 4500.15.

0-4. Administrative Storage

Before placing the TA-885/U in temporary storage (90 days), determine the serviceability of the equipment by performing the checks in paragraphs 5-7 through 5-13.

0-5. Destruction of Army Electronics Materiel

Destruction of Army electronics materiel shall be in accordance with the instructions in TM 750-244-2.

0-6. Reporting Equipment Improvement Recommendations (EIR)

If your TA-885/U needs improvement, let us know. Send us an EIR. You, the user, are the only one who can tell us what you don't like about your equipment. Let us know why you don't like the design. Tell us why a procedure is hard to perform. Put it on an SF 368 (Quality Deficiency Report). Mail it to Commander, US Army Communications and Electronics Materiel Readiness Command, ATTN: DRSEL-ME MQ, Fort Monmouth, New Jersey 07703. We'll send you a reply.

0-7. Items Comprising an Operable Equipment

Audio Level Meter TA-885/U includes the meter, with cover and a power cord. The power cord is stored inside the cover of the set.

Table 1-1. Specifications

<p>VOICE FREQUENCY LEVEL MEASUREMENTS (20Hz to 20kHz)</p> <p>Range: -91dBm to +31dBm</p> <p>Level accuracy: 20Hz to 20kHz: +0.5dB 40Hz to 15kHz: +0.2dB (Levels greater than -60dBm)</p> <p>Note: For levels greater than +1 dBm, level accuracy specification applies only for frequencies above 100Hz.</p> <p>Input: will terminate or bridge 600 ohms or 900 ohms balanced. Bridging loss: less than 0.3 dB at 1kHz. Return loss: 30dB min. (50Hz to 20kHz) TERM Return loss: 30dB min. (50Hz to 2kHz) TERM only. Balance: greater than 80dB at 60Hz greater than 70dB to 6kHz greater than 50dB to 20kHz Holding circuit: 700 ohms dc resistance, 60mA max. loop current at 300Hz. With holding circuit in, above specs apply from 300Hz to 4kHz.</p> <p>NOISE MEASUREMENTS</p> <p>Range: -1 dBm to +121dBm</p> <p>Weighting filters: 3kHz flat, 15kHz flat, C-message, and program. Meets joint requirements of Edison Electric Institute and Bell Telephone System.</p> <p>Input: same as for level measurements.</p> <p>Noise to ground: 80 kilohms across line 100 kilohms to ground -40dB relative to 600 ohms noise metallic at 1kHz.</p> <p>CARRIER FREQUENCY LEVEL MEASUREMENTS (30Hz to 3MHz)</p> <p>Range: -61dBm to +11dBm</p> <p>Level accuracy: 600 ohms balanced 1kHz to 150kHz: ±0.5dB 135 ohms balanced (or 150 ohms balanced) 1kHz to 600kHz: ±0.5dB 10kHz to 300kHz: ±0.2dB 75 ohms unbalanced 100Hz to 600kHz: ±0.2dB 30Hz to 1MHz: ±0.5dB 1MHz to 3MHz: ±0.5dB ±10% of meter reading in dBm.</p> <p>Input: will terminate or bridge 600 ohms or 135 ohms</p>	<p>balanced and 75 ohms unbalanced. Return loss: TERM ONLY 600 ohms: 26dB min 3kHz to 150kHz 135 ohms: 26dB min to 600kHz 75 ohms: 30dB min to 3MHz Bridging loss: less than 0.05dB at 10kHz Balance: greater than 70dB to 10kHz greater than 60dB to 100kHz greater than 40dB to 600kHz</p> <p>GENERAL</p> <p>Temperature range: 0°F to 120°F 0 to 95% relative humidity The 3555B will operate at -40°F under reduced specifications. At this temperature, attention should be given to noting condition of battery as indicated on Battery Test (DIAL/BAT).</p> <p>Meter: linear dB scale indicates rms value of input signal. 12dB range.</p> <p>Meter response Normal: 200ms to indicate a reading to 0dBm on meter. Damp: 500ms to indicate a reading to 0dBm on meter.</p> <p>Maximum input voltage Tip to ring: 150V peak Tip or ring to ground: 500V peak (This is maximum instantaneous voltage. Input circuit will withstand 48V dc CO battery with superimposed 90V rms 20Hz ringing voltage or ±130V carrier supply.)</p> <p>Maximum longitudinal voltage: 200V rms at 60Hz</p> <p>AC Monitor: 0.27V rms for 0dBm on meter. $R_{out} = 8$ kilohms. Available at DIAL/AC MON jacks. Sufficient to drive WE 1011B or 52 type headset.</p> <p>DC Monitor: 1 volt for 0dBm on meter. $R_{out} = 2$ kilohms. Jack accepts 310 plug (tip negative).</p> <p>Input jacks: will accept Western Electric (WE) 241, 309, 310, 358 plugs. Binding posts accept banana plugs, spade lugs, phone tips or bare wires. Removable shorting bar between sleeve and ground binding posts.</p> <p>Dial/AC Monitor jacks: will accept WE 289, 310, 347 plugs. Accepts WE 1011B lineman's handset or 52 type headset.</p> <p>Power requirements: Internal battery: single NEDA 202 45V "B" battery included. Expected battery life - 180 hours at 4 hours per day at 70° F. AC: 115V or 230V, 48-440Hz, <1W External battery: 24V or 48V office battery; jack accepts 310 plug (tip negative) less than 15mA.</p>
--	--

SECTION I GENERAL INFORMATION

1-1. INTRODUCTION.

1-2. The Hewlett-Packard Model 3555 B Transmission and Noise Measuring Set is a versatile set designed for uses in testing telecommunications equipment. The extreme sensitivity of this set, linked with its wide and flat frequency response, make it suitable for noise and level measurements at voice, program and carrier frequencies. Levels from -80dBm to +30dBm (10dBm to +120dBm) full-scale can be measured and displayed on a meter calibrated to indicate both in dBm for level measurements and in dBm for noise measurements.

1-3. The set combines the features of a voice and noise frequency measuring set and the features of a carrier frequency measuring set. For voice and program frequencies impedances of 900 ohms and 600 ohms are

provided, balanced or unbalanced, bridged or terminated. For noise measurements a noise-to-ground (Ng) function is provided which provides 40dB of attenuation for longitudinal noise. For carrier frequencies 600 ohm, 135 ohm and 75 ohm impedances are provided. The 600 and 135 function can be either balanced or unbalanced, bridged or terminated; The 75 function is unbalanced only. Bridging impedance is over 100 kilohms, allowing measurements with a bridging loss of less than 0.05dB. The meter indicates in dBm for any selected input impedance.

1-4. The 3555B includes a 3kHz flat, a C-Message, a Program and a 15kHz flat filter, each easily selectable by a front panel control. These filters conform to the standards set up .by the Bell System and Edison Electric Institute. Other filters are available upon request.

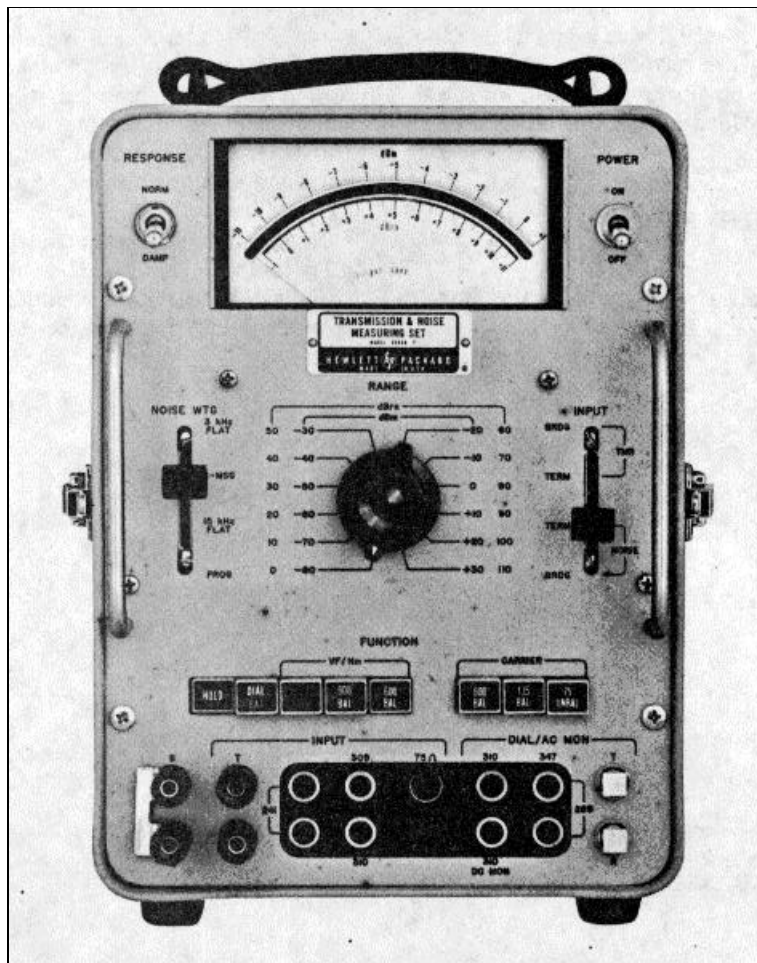

Figure 1-1. Model 3555B Transmission and Noise Measuring Set

1-5. A noise-to-ground (Ng) function is included which permits the measurement of longitudinal noise. When making noise-to ground measurements the impedance between INPUT terminals is greater than 80 kilohms and is 100 kilohms between each terminal and ground. A HOLD function permits holding the line while noise measurements are being made. The input circuitry provides 40dB of longitudinal noise attenuation when noise-to-ground measurements are being made.

1-6. A DIAL/BAT function permits connecting a lineman's handset to the line for the purpose of dialing and at the same time connects the front panel meter to the power supply so that the battery voltage or unregulated power supply voltage can be monitored.

1-7. Jacks accepting Western Electric type 241, 309, 310, 347, and 358 plugs are provided for INPUT connections to the 3555B. Dual binding posts accept banana plugs, wires, lugs or phone tips and a pair of special connectors permit the attachment of clip leads from a lineman's handset.

1-8. The Model 3555B can be operated from either the internal 45V dry cell battery or from the ac line, 115 or 230Vac, 48Hz to 440Hz. A special device is included in the cover to automatically turn the set off when the cover is replaced. The set can also be operated from the central office battery. A jack is provided on the side of the set for this purpose.

1-9. ACCESSORY EQUIPMENT SUPPLIED.

1-10. The accessory equipment supplied with the Model 3555B is listed in Table 1-2.

Table 1-2. Accessory Equipment Supplied

-hp- Part No.	Description	Quantity
8120-1348	Power Cord	1
1470-0026	Battery, 45 Volt dry cell	1
03555-26510	Test Board	1
5000-7135	Decal, 150 BAL	1

1-11. INSTRUMENT IDENTIFICATION.

1-12. Hewlett-Packard uses a two-section serial number. The first section (prefix) identifies a series of instruments. The last section (suffix) identifies a particular instrument within the series. If a letter is included with the serial number, it identifies the country in which the instrument was manufactured. If the serial prefix of your instrument differs from the one on the title page of this manual, a change sheet will be supplied to make this manual compatible with newer instruments or the backdating information in Appendix C will adapt this manual to earlier instruments. All correspondence with Hewlett-Packard should include the complete serial number.

1-13. 150 BAL MODIFICATION.

1-14. The Model 3555B is shipped from the factory with a 135 BAL function. If a 150 BAL function is desired instead of the 135 BAL function, the set can be converted by simply clipping a shorting wire within the set, applying a 150 BAL decal (supplied with the set) over the 135 BAL decal and making only one adjustment.

1-15. For detailed instructions on modification of the set refer to Paragraph 5-6. If your set is known to be within specification tolerances a simplified procedure can be used to modify the set and is described in Paragraph 3-69.

**SECTION II
INSTALLATION**

2-1. INSPECTION.

2-2. The set was carefully inspected both mechanically and electrically before shipment. It should be physically free of marks or scratches and in perfect electrical condition on receipt. To confirm this, the set should be inspected for physical damage in transit, for supplied accessories and for electrical performance. Paragraph 5-7 outlines the electrical performance checks using test equipment listed in Table 5-1. If there is damage or deficiency, see the warranty in the front of this manual.

2-3. WARRANTY EXCEPTION.

2-4. The battery supplied with the 3555B is warranted for a period of 60 days, beginning at the time of receipt of the set. This warranty is based on an expected battery life of 180 hours at 4 hours per day at 700 F as specified in Table 1-1 in this Manual.

2-5. POWER REQUIREMENTS.

2-6. This set is designed to operate from an internal 45 volt dry cell battery, an external 24 to 48 volt CO battery or from an ac power source (115/230V, 48 to 440Hz). The power source is selected by the AC/BAT switch on the side of the set. The line voltage is selected by the 115/230 volt slide switch on the rear of the set. The set is protected by a 0.1 5A slow-blow fuse.

2-7. THREE-CONDUCTOR POWER CABLE.

2-8. To protect operating personnel, the National Electrical Manufacturers' Association (NEMA) recommends that the panel and cabinet be grounded. This set is equipped with a three-conductor power cable which, when plugged into an appropriate receptacle, grounds the set. The offset pin on the power cable three-prong connector is the ground wire. This power cable is detachable from the set and is stored inside the front cover.

2-9. Figure 2-1 illustrates the standard power plug configurations that are used throughout the United States and in other countries. The -hp part number shown directly below each plug drawing is the part number for a 3555B power cord equipped with the proper plug. If the appropriate power cord is not included with the instrument, notify the nearest Hewlett-Packard office and a replacement cord will be provided.

Table 2-1. Suitable Batteries Meeting NEDA 202 Specifications

Manufacturer	Mfr. Part No.
Hewlett-Packard	1420-0026
Western Electric	KS-14370
Military	BA-59
Eveready	482
Burgess	M-30
RCA	VS013
Bright Star	3033-158, 30-33
Mallory	M-202
Ray-O-Vac	202, P7830
Sears	6461
Wards	42
Wizard	3B6241
Zenith	2783
General	W30B
Marathon	4202
National Carbon	482

2-10. BATTERY.

2-11. This set is operated from a single NEDA 202 45V dry cell internal battery or an external 48V CO battery when the power selection switch, on the side of the case, is in the DIAL/BAT position. Inserting a Western Electric plug into the battery jack disconnects the internal battery. (See Table 2-1 for batteries suitable for use in this instrument.)

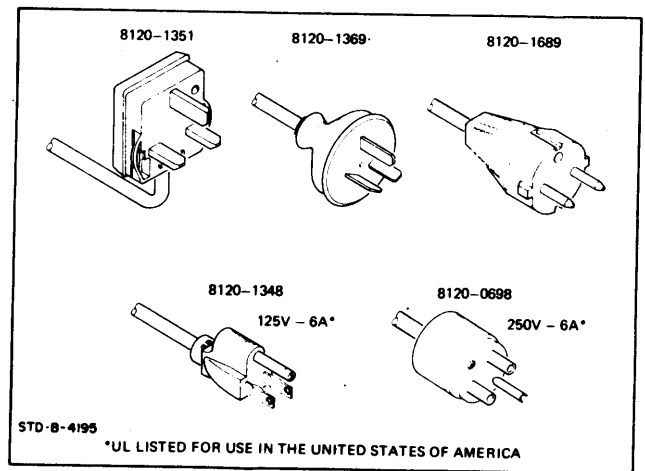

Figure 2-1. Power Plugs.

2-12. INSTALLATION AND REMOVAL OF BATTERY.

2-13. To install or replace a battery, turn the four 1/4 turn fasteners on the battery cover on the rear of the case counterclockwise to remove the cover. Lift off the cover, lift the battery out of its recess and unplug the three-prong connector.

2-14. Reverse the above procedure when installing a new battery.

2-15. COVER REMOVAL.

2-16. To remove the cover from the instrument, release the two spring latches on either side of the instrument, then lift cover. When replacing the cover, first check the latches for released position; then place cover in position for latching. The power cord is stored inside the cover by wrapping it around the retainer fastened inside the cover.

CAUTION

DO NOT FORCE COVER INTO PLACE. THERE IS A PROJECTION ON THE COVER WHICH TURNS THE POWER SWITCH TO THE OFF

POSITION TO PRESERVE BATTERY LIFE. IF THIS IS NOT BINDING, THE COVER FITS EASILY INTO PLACE.

2-17. REPACKAGING FOR SHIPMENT.

2-18. The following is a general guide for repackaging at instrument for shipment. If you have any questions, contact your local Sales and Service Office. (See Appendix for locations.)

- a. Place instrument in original container if available. If not available, one can be purchased from your nearest -hp- Sales and Service Office.
- b. Wrap instrument in heavy paper or plastic before placing in inner container.
- c. Use plenty of packing material around all sides of instrument.
- d. Use a heavy carton or wooden box to house the instrument and inner container and use strong tape or metal bands to seal the shipping container.
- e. Mark shipping container with "Delicate Instrument" or "Fragile".

SECTION III OPERATING INSTRUCTIONS

3-1. INTRODUCTION.

3-2. The Model 3555B Transmission and Noise Measuring Set is an extremely versatile transmission and noise measuring set which satisfies many of the requirements in testing telecommunications equipment. The 3555B features a choice of 900 or 600 ohms bridging or terminated for voice frequencies and 600, 135 or 75 ohms bridging or terminate for carrier frequencies. Noise-to-ground and noise Metallic may be measured with 3kHz Flat, C-Message or 1 5kHz Flat weighting. A HOLD function permits seizing the line while measurements are being made at voice and program frequencies. The set is portable and operates from the internal battery, office battery or ac power source.

3-3. This section of the manual contains all the information necessary in the operation of the 3555B along with a description of all controls, connectors and indicators.

3-4. CONTROLS, CONNECTORS AND INDICATORS.

3-5. Figure 3-1, 3-2 and Table 3-1 illustrate and describe the function of all front and side panel controls, indicators and connectors.

3-6. OPERATION.

3-7. To operate the Model 3555B, refer to figure 3-1 and perform the following steps:

- a. Before connecting the 3555B to an ac power source, insure that the 115/230 volt switch is positioned to indicate the line voltage to be used. Some earlier instruments did not have the 115/230 volt selector switch. To change these instruments, jumper wires must be changed on the power transformer. Refer to Appendix C for a wiring diagram of the two configurations.
- b. If the set is to be operated from the internal battery or from an external office battery, place the AC/BAT switch (located on the side of the set) to the BAT position, using a small pointed object; if the set is to be operated from the ac line, place the AC/BAT switch to the AC position. For operation from a 24 or 48V office battery, connect a patch cord with a Western Electric 310 plug to the battery jack on the side of the case and then connect the cord to the office battery on the test board or bay. Inserting the plug disconnects the internal battery. The office battery is

arranged for -48V or -24V $\pm 2V$ with the negative terminal of the battery connected to the tip and the ground terminal connected to the sleeve. Current consumption by the 3555B is approximately 15mA.

WARNING
DURING BATTERY OPERATION, THE "G" BINDING POST MUST BE CONNECTED TO EARTH GROUND.

CAUTION
THE CORD MUST BE CONNECTED TO THE MEASURING SET BATTERY JACK FIRST AND THEN PLUGGED INTO THE BATTERY SUPPLY TO AVOID SHORTING THE OFFICE BATTERY TO GROUND.

- c. Turn the POWER switch to ON and depress the DIAL/BAT pushbutton on the FUNCTION switch. The meter pointer should indicate in the BAT GOOD area indicating that the battery condition is good if the set is being operated from the internal battery. The meter will also monitor the ac supply voltage or the external office battery voltage, providing an indication of low voltage should it exist. The voltage should cause meter deflection above the lower end of the green BAT GOOD area for proper set operation.

3-8. BATTERY.

3-9. The internal dry cell battery has a voltage range between 45 volts when new to 24 volts at cut-off which is the end of useful life. The cut-off voltage corresponds to the left end of the green BAT GOOD area on the meter. The condition of the battery and the approximate time to cut-off can be estimated by observing the position of the meter pointer in the BAT GOOD area.

3-10. The internal battery is of the carbon-zinc type with its attendant limitations due to temperature. The service obtained from carbon-zinc batteries depends on factors such as current drain, discharge temperature, discharge time and storage prior to use. The battery supplied with the 3555B should provide in excess of 180 hours of operation based on a 4 hours/day duty cycle at 77° F (25° C). At other temperatures this time will change. At temperatures above 131° F (55° C) the batteries may fail suddenly while at temperatures below 40° F (-20° C), the service life will be short.

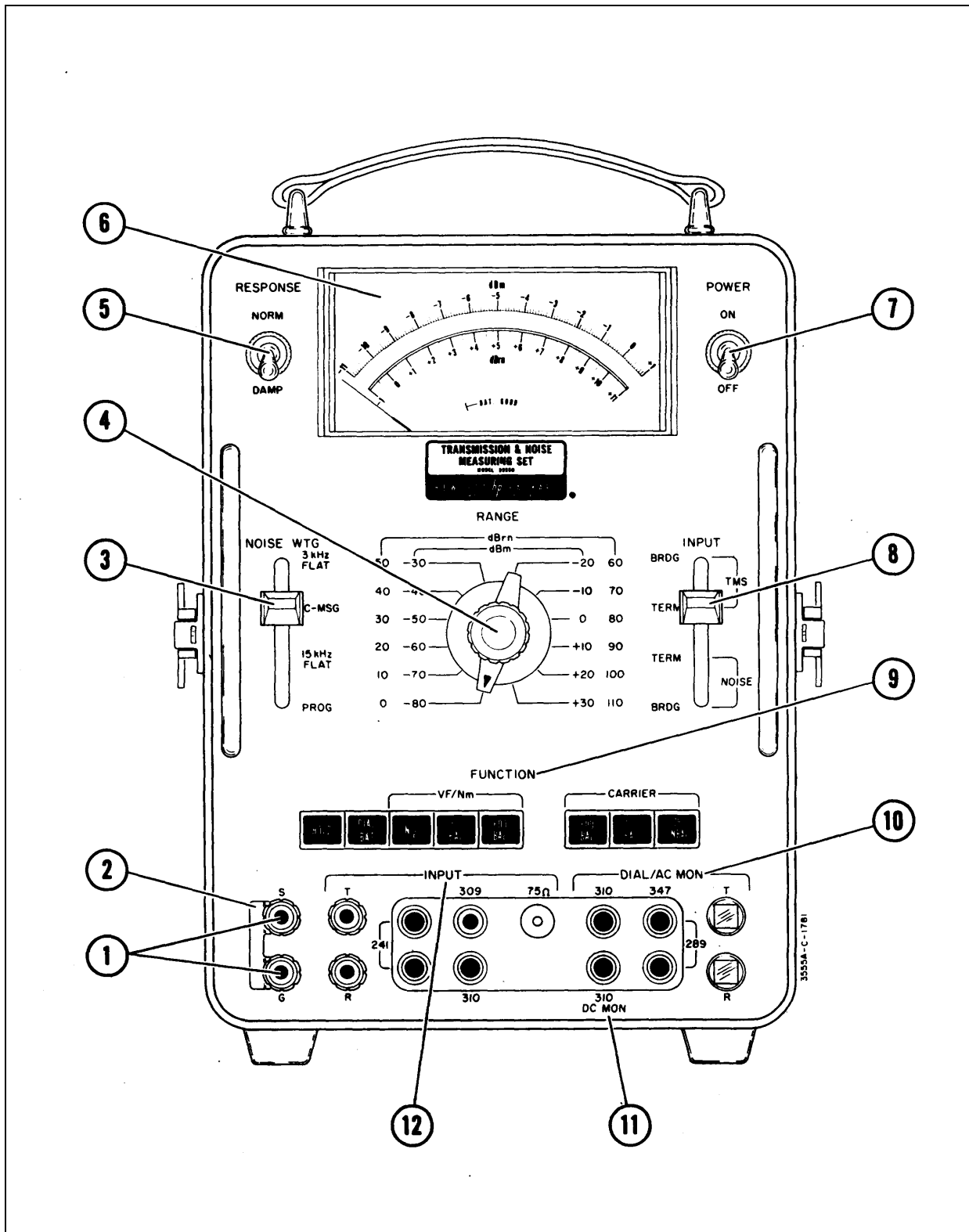

Figure 3-1. Front Panel Controls, Indicators, and Connectors

Table 3-1. Front, Side and Rear Pane

<p>(1) S and G Jacks: Binding posts accepting banana plugs, spade lugs, phone tips or bare wires for connection to the case ground (G) and sleeves (S) of all INPUT jacks (12) and DIAL/AC MON jacks (10) and (11).</p> <p>(2) Shorting Strap: A swing-away shorting strap connecting the S and G terminals together which may be used to isolate the jack sleeves from case ground. Not for use with type 347 plugs.</p> <p>(3) WTG Switch: Selects weighting filters for noise measurements. These filters are selectable only when the INPUT switch is in one of the two NOISE positions. The 3kHz FLAT, C-MSG, 15kHz FLAT and PROG filters all conform to the standards set up by the Bell System and Edison Institute for measuring message circuit noise.</p> <p>(4) RANGE SWITCH: Selects dBm or dBm ranges of input sensitivity. The RANGE switch markings correspond to the 0 markings on the meter scale (6). The black markings are dBm for transmission measurements and the blue markings are dBm for noise measurements.</p> <p>(5) RESPONSE Switch: Selects NORM meter response for transmission level measurements or DAMP for noise measurements where noise is impulsive in nature.</p> <p>(6) Meter: A taut band individually calibrated meter with shaped pole pieces to provide a linear dBm indication with equal accuracy and resolution over the entire meter scale. The dBm scale is marked in black and has 0.1dB resolution for transmission measurements. The 0 marking at the right end of the scale corresponds to the black RANGE switch setting. The dBm scale is marked in blue for noise measurements. The 0 marking at the left end of the scale corresponds to the blue RANGE switch setting. The green arc marked BAT GOOD corresponds to the green DIAL BAT pushbutton for checking the power source. The left edge of the arc corresponds to the battery cut-off voltage of 24 volts and the right edge (meter full-scale) represents 60 volts which is the maximum voltage that can be used to power the set without internal damage.</p> <p>(7) POWER ON/OFF Switch: turns on all power to the set. The set operates from either 115 volts or 230 volts ac, the internal 45 volt dry cell battery or from an external office battery supply.</p> <p>(8) INPUT Switch: Selects TMS, either BRDG or TERM for transmission measurements and NOISE, either BRDG or TERM for noise measurements. For noise measurements the switch must be in</p>	<p>Controls, Indicators and Connectors either the NOISE BRDG or the NOISE TERM before the NOISE WTG filters can be selected.</p> <p>(9) FUNCTION Switch: A series of interlocking pushbutton switches (with the exception of the HOLD switch which is push-push type) with the following functions:</p> <ol style="list-style-type: none"> a. VF/Nm <ol style="list-style-type: none"> 1. HOLD: Applies a dc holding bridge across the metallic line for the NG, 900 and 600 functions. The HOLD pushbutton is the push-push type, ie, push to make and push to break. The HOLD function cannot be accomplished when any one of the CARRIER pushbuttons is depressed. 2. DIAL/BAT: Connects the multiple INPUT jacks in parallel with the DIAL/AC MON jacks for the dial and talk operation. The circuit is arranged for loop dialing and the line under test must supply talk battery. Connects the meter circuit and a load to the internal power supply to check the condition of the battery, ac power or external office battery as indicated on the green meter scale. POWER (7) must be ON for the battery test. 3. NG: Selects the noise-to-ground input circuits for measuring longitudinal noise. Attenuation of 40dB is inserted by this circuit. Earth ground should be connected to the black G binding post (1) 4. 900: Selects the input circuitry for balanced 900 ohm circuits. This function selects a low frequency transformer for voice frequencies. Response of this transformer is 20Hz to 20kHz. 5. 600: Selects the input circuitry for balanced 600 ohm circuits. A low frequency transformer is selected for this function. b. Carrier <ol style="list-style-type: none"> 1. 600: Selects the input circuitry for balanced 600 ohm circuits. A high frequency transformer is selected for this function. Response of this transformer is 1kHz to 600kHz. The HOLD function is not operative in any of the carrier functions.
---	---

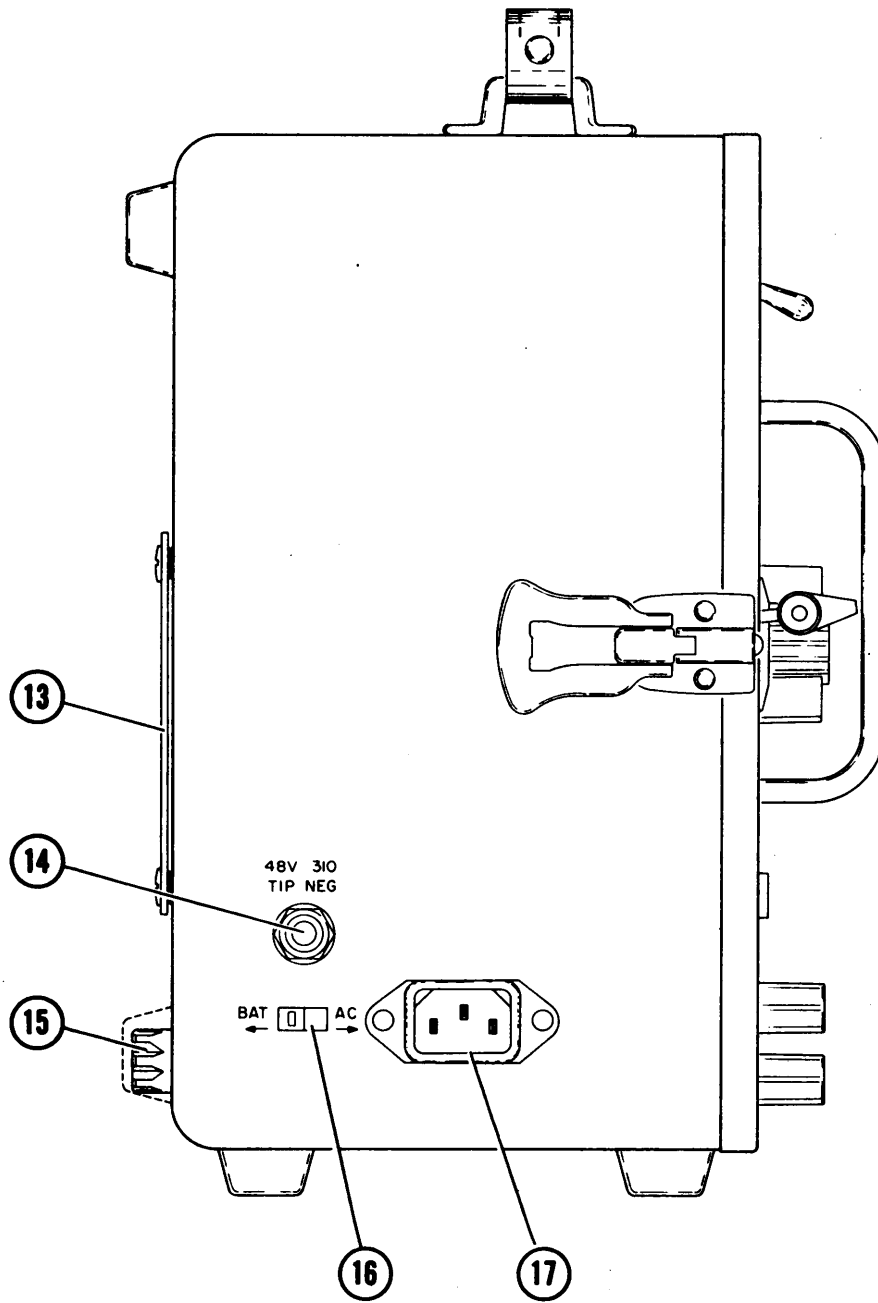

Figure 3-2. Side Panel Controls and Connectors

Table 3-1. Front, Side and Rear Panel Controls, Indicators and Connectors (Cont'd)

<p>2. 135: Selects the input circuitry for 135 ohm balanced circuits. A high frequency transformer is selected for this function.</p> <p>3. 75: Selects the input circuitry for 75 ohm unbalanced operation. Only the 75 ohm jack can be used for this function. This function does not utilize an input transformer, therefore the maximum bandwidth is available on this function. This jack accepts a 358 plug.</p> <p>(10) DIAL/AC MON: A set of multiple jacks accepting Western Electric type 310 or 347 plugs, 289 dual plugs and a pair of special clip posts marked T and R which accept a Western Electric 1011B lineman's handset for the dial and talk operation when the FUNCTION pushbutton marked DIAL/BAT is depressed. Loop dialing is used and the circuit must supply talk battery. When any other FUNCTION pushbutton is depressed, the tip and ring of these jacks are connected to the AC MON output of the internal amplifiers for monitoring purposes.</p> <p>(11) DC MON: Accepts a Western Electric 310 or 347 plug for tip negative and sleeve connections to an external dc recorder. Output voltage is proportional to the input voltage on any one setting of the RANGE switch.</p> <p>(12) INPUT: A set of multiple jacks accepting Western Electric 241 (or 289), 309, 310 and 358 plugs and a pair of binding posts marked T and R for banana plugs, spade lugs, phone tips or bare wires</p>	<p>providing connection to the input circuitry of the measuring set. When the DIAL BAT pushbutton is depressed, the INPUT jacks are connected in parallel with the DIAL/AC MON jacks.</p> <p>(13) Battery Cover: Removeable by four 1/4 turn screw fasteners to expose the internal battery for replacement.</p> <p>(14) 48V 310: A jack accepting a Western Electric 310 plug with tip negative and sleeve ground to supply external office battery power to the set. Insertion of a 310 plug into this jack disconnects the internal battery. The BAT-AC switch (16) must be set to BAT for office battery operation.</p> <p style="text-align: center;">CAUTION</p> <p style="text-align: center;">WHEN OPERATING FROM AN EXTERNAL BATTERY, CORD SHOULD BE CONNECTED TO MEASURING SET FIRST, THEN PLUG INTO BATTERY SUPPLY TO AVOID SHORTING THE OFFICE BATTERY.</p> <p>(15) 0.15A-SPARE Fuse: A 0.15A slo-blo fuse and a spare for measuring set protection when operating from AC power. Fuses are not used when the set is battery powered.</p> <p>(16) BAT-AC Switch: A slide switch for selecting the ac power source or the internal battery and office battery jack, (14), power source. The switch may be operated by a small screwdriver or pointed tool inserted into the slot in the switch.</p> <p>(17) AC Power Receptacle: A 3 prong power receptacle for the special power cord stored inside the front cover. The BAT-AC switch (16), must be positioned to AC for this power source.</p>
--	--

3-11. High storage temperature is damaging to dry cells and tends to reduce shelf life. Low storage temperature is beneficial to battery life although the battery should be warmed to room temperature prior to use. Turning off the set when not in use and consideration of the above factors will maximize battery life. The instant turn characteristics of this set with no warm-up time required allows turning off between measurements.

NOTE

If the battery voltage indication drops below the left end of the arc on the meter face the set will not operate properly. This will be noted by a slow oscillation of the meter. If this symptom is encountered, depress the DIAL/BAT pushbutton and check the battery condition. If the indication is to the left of

the arc on the meter face, replace the battery.

3-12. LEVEL AND NOISE MEASUREMENTS.

3-13. Since the 3555B is both a level measuring set and a noise measuring set, the procedure for making these measurements will be treated separately. Level measurements can be made at voice frequencies and carrier frequencies. Since the procedure for making voice and Carrier level measurements are identical except for the FUNCTION pushbutton utilized, only one procedure will be described in detail.

3-14. LEVEL MEASUREMENTS.

3-15. The 3555B can be used as a wide range and wide

frequency Transmission Measuring Set (TMS) for voice, program and carrier multiplex measurements. The set will operate over a wide range of environmental conditions and maintain a high degree of accuracy.

3-16. In general, transmission level measurements are made by connecting the circuit under test to the INPUT jacks with a suitable patch cord, selecting the proper bridging or terminate condition and impedance, and then operating the RANGE switch to provide an on-scale meter indication. Transmission level measurements are made with the INPUT switch in TMS position either bridging or terminated. In this position, the set has its maximum frequency range.

3-17. The multiple INPUT jacks and binding posts accept the Western Electric 309, 310 and 358 single plugs and the 241 or 289 twin plug. The two red binding posts marked T (tip) and R (ring) will accept banana plugs, spade lugs, phone tips or bare wires. These jacks and binding posts are all connected in parallel and only one should be used at a time. A patching cord such as the Western Electric 3P12H, consisting of a cord with a 310 plug on one end and a 309 plug on the other end, should be kept with the instrument as a universal patch cord. The 75 ohm jack accepts Western Electric type 358 plugs for 75 ohms. unbalanced carrier measurements.

3-18. The sleeves of all the INPUT and DIAL jacks are connected together and to the black binding post marked S. The binding post in turn, is connected through a swing-away shorting strap to a second black binding post marked G. This binding post is the measuring set case ground. When it is necessary to establish a battery or ground connection on the sleeve for PBX test purposes, this shorting strap may be disconnected by loosening the black binding posts and swinging away the strap. A cord is then connected to the S terminal and may be connected to the battery or ground for the test. Type 347 plugs must not be used when the shorting strap is removed.

3-19. The multiple jacks marked DIAL/AC MON are connected in parallel and accept a 310 or a 347 single plug or a 289 dual plug. A dial with the impulse springs connected to the tip and ring of a 310 or 347 plug may be used or a lineman's handset such as the Western Electric 1011 B may be connected to the two square clip posts for the dialing and talk operation. When the FUNCTION pushbutton marked DIAL/BAT is depressed, the DIAL jacks are connected to the INPUT jacks and a number may be dialed on the line connected to the INPUT jacks. The circuit is arranged for loop dial operation and the circuit under test must supply talk battery.

3-20. Once the switching equipment has been seized by the dialing operation, the connection can be held by depressing the HOLD pushbutton. This places a dc bridge consisting of a high impedance retardation coil, across the INPUT terminals. This coil has negligible effect on measurements of voice frequencies. Once any other pushbutton is depressed, the AC output of the internal amplifier circuit is returned to the DIAL/AC MON jacks for an external head Model 3555B phone which can be used to monitor the noise or tones being measured. The

lineman's hand set which was used for the dialing operation can be used for monitoring by leaving it connected to the clip posts. The jacks marked 310 will accept a head phone or recorder connected to the tip and ring of a 310 plug or tip and sleeve of a 347 plug. The performance of the set is not affected by this output and any impedance head-phone may be used.

3-21. The DIAL/BAT function also checks the power source used. The green arc on the meter marked BAT GOOD corresponding to the green BAT marking on the pushbutton, indicates the range of voltages for proper operation. Full scale corresponds to 60 volts and the left end of the arc corresponds to the battery cut-off voltage of 24 volts. Thus the remaining battery life can be estimated by noting the position of the pointer in the green arc. Since the set POWER must be turned ON to perform this check, the battery is properly loaded to give a true indication of its condition. When operating from the external office battery or AC power, the meter monitors this voltage to indicate if it is the correct level to properly power the set. The POWER switch turns OFF and ON all power to the set.

3-22. The remaining FUNCTIONS are used to set up the input conditions. The Ng function will be discussed under the paragraph heading, "NOISE MEASUREMENTS". The impedance of the set is selected by the pushbuttons marked 900 and 600 for voice frequencies and 600, 135 and 75 for carrier frequencies. The 900 and 600 ohm impedances are normally used for loop plant testing while 600, 135 and 75 ohms are usually reserved for carrier system measurements. A bridged or terminated condition is determined by the position of the INPUT switch. Using this procedure, the meter will always indicate in dBm for the impedance selected, bridging or terminated. The terminations, when used, are provided with a dc blocking capacitor. Accidental application of carrier or telegraph battery, office battery or ringing voltage will not damage the set. The pushbutton marked HOLD bypasses the INPUT switch and terminates the circuit in addition to placing the holding bridge across the line that is connected to the INPUT. When the INPUT switch is in either of the NOISE positions, weighting filters can be selected by the NOISE WTG switch for noise measurements.

3-23. The RANGE switch selects the dBm range of the meter. To avoid overloading the set, turn the RANGE switch to +30dBm when connecting a circuit for testing. Once the circuit connection is established turn the RANGE switch counterclockwise until an on-scale indication is obtained. The black dBm marking on the RANGE switch identifies the input level required to deflect the meter to the 0 mark on the black scale. The meter uses shaped pole pieces to present linear dBm markings on the scale with marks at 0.1 dBm increments. The accuracy and resolution of this type of meter is the same at any point on the scale and it is not necessary to keep the pointer in the upper portion of the scale for maximum accuracy. The accuracy of the set is not affected by the position of the set. This type of meter will have the pointer off-scale to the left

when no input signal is present and a mechanical zero adjust is not required. The actual input level to the set is the algebraic sum of the black dBm meter scale and black RANGE setting. For example, RANGE is set to 40dBm and the meter indicates -6.3dBm. The input level is then $(-40) + (-6.3) = -46.3\text{dBm}$. If the RANGE switch is at +20dBm and the meter indication is 4.7dBm, the level is $(+20) + (4.7) = +15.3\text{dBm}$.

3-24. All panel markings corresponding to the proper dBm markings on the RANGE switch and meter face are in black, as is the TMS position of the INPUT switch. The blue markings correspond to the settings for noise measurements as discussed in paragraph 3-28. The response of the meter rectifier circuit is RMS which allows the set to measure the true power of any arbitrary input waveform provided the crest factor does not exceed 4:1. Crest factor is defined as the ratio of the peak value of the waveform to the RMS value of that waveform. In most telephonic measurements, consideration of this crest factor is not necessary.

3-25. The balanced input to the set is achieved through the use of two repeat coils, one for voice frequencies from 20Hz to 20kHz and the other for carrier frequencies from 10kHz to 600kHz. The maximum high frequency range is achieved through the use of the 75 ohm functions and the 75 ohm jack. This input bypasses both input repeat coils, thus allowing measurements from 30Hz to 3MHz. This high frequency range is limited to 600kHz on the +20 and +30dBm ranges. The maximum longitudinal input voltage is 150 volts peak between tip and ring and 200 volts rms at 60Hz between either tip or ring and ground.

3-26. The switch marked RESPONSE determines the speed of the meter response and is usually left in the NORM position for transmission measurements.

3-27. The jack marked DC MON accepts a Western Electric 310 or 347 plug with connections to the tip and sleeve. The dc voltage supplied by this jack can be used to operate a dc potentiometric recorder requiring 1V or a dc galvanometric recorder requiring 500uA. The dc output is proportional to input level on any one range and not meter deflection since the meter is logarithmically scaled. Knowing the current required to drive the recorder full scale and the input impedance of the recorder, enter these numbers into the recorder compatibility chart Figure 3-4 to determine if the recorder is suitable for use with this set. If these numbers do not fall within the compatibility area, refer to Paragraph 3-41. Connect an input voltage to the set and adjust the RANGE switch until a near full scale indication is observed on the meter. Connect the recorder plug with the tip negative to the DC MON jack and adjust the input level until the meter indicates 0dBm. Mark this point, which should be near full scale, on the recorder paper. Decrease the input level until the meter indicates -1dBm. Mark this point on the recorder paper. Continue until the recorder has been calibrated for each major dBm division on the meter. The actual input level to the set as

indicated on the recorder will be the algebraic sum of the RANGE.

3-28. NOISE MEASUREMENT.

3-29. One of the primary functions of this set is to measure message circuit noise, both metallic and noise-to-ground. The weighting filters built into this set are switch selected and their characteristics conform to the standards set up by the Bell System and Edison Electric Institute.

3-30. In general, noise-metallic measurements are made by connecting the circuit under test to the INPUT jacks with a suitable patch cord, selecting the proper bridging or terminate condition and impedance, selecting the proper weighting filter and operating the RANGE switch to provide an on-scale meter indication. Noise measurements involve many of the same operations as the level measurements discussed in Paragraph 3-14 and only the differences will be discussed.

3-31. Four filters are supplied for noise measurements; C-MESSAGE and 3kHz FLAT for message circuit noise measurement, a PROG and 15kHz FLAT for broadcast studio-transmitter links and telephone company program circuits. These filters are necessary to allow the measuring set to approximate the response of the human ear and give an indication representative of a person's subjectiveness to noise. The frequency response of these filters is shown in Figures 4-5 and 4-6.

3-32. Once a circuit has been connected, the RANGE switch is adjusted until the noise fluctuations appear on-scale on the meter with normal response, and a two-to-three minute observation of the pointer fluctuations is made to establish the point at which the pointer appears most of the time, disregarding the occasional high peaks. For rapidly fluctuating noise such as atmospheric static or switching noise, operate the RESPONSE switch to DAMP. In this position of the switch, the level of the most frequently occurring peaks should be read. Noise is specified in dBm (decibels above reference noise) and the type of filter used is noted, for example, dBmC meaning C-message weighting is used.

3-33. The noise-metallic level is the algebraic sum of the indication on the blue dBm meter scale and the blue dBm RANGE switch setting. For example, RANGE is set to 20dBm and the meter indicates +7dBm. The noise-metallic level is $(20) + (+7) = +27\text{dBm}$. The RANGE switch marking indicates the level at the 0dBm mark on the left end of the meter scale.

3-34. Occasionally other message circuit weightings such as the older Bell System F1A weighting or the International Telecommunication Union's CCITT or psophometric weighting may be required. To convert from C-message to F1A, subtract 6dBm from the C-message indication. The units for F1A weighting are dBa, meaning decibels adjusted. To convert from C-message to CCITT or psophometric weighting, subtract 1dBm from the C-message level as read on the black dBm meter scale and RANGE switch setting. This will give the noise level in dBm which is acceptable for psophometric measurements.

Section III

3-35. As an aid in identifying the source of noise, the DIAL/AC MON jacks can be used with a monitoring receiver to listen to the noise which will have approximately the same quality as that heard by a subscriber. Particular types of noise like power line induction, switching noise, atmospheric static, crosstalk or random noise may be identified by this listening test. To aid in bringing up the level of the lower frequency power line noise, the 3kHz flat weighting is used. A substantial increase in meter indication with the 3kHz flat weighting indicates the presence of low frequency noise and it will also sound louder in the monitoring headphone.

3-36. In some cases recording of the noise during a busy period is necessary. The recorder connections and operation is discussed in Paragraph 3-27. The calibration should be done using the dBm scale rather than the dB scale and it should be noted that the RESPONSE switch also damps the recorder.

3-37. Noise-to-ground measurements are made by a special input circuit arrangement which is used when either the Ng or Ng HOLD pushbutton is depressed. Dial and talk may be accomplished on the metallic circuit and the metallic connection held by using the Ng HOLD pushbutton. It is necessary to establish a good earth or system ground and connect it to the black binding post marked G. The noise-to-ground measurement is 40dB less sensitive than the noise metallic measurement because of the voltage divider in the input circuit. This requires adding 40dB to the meter indication to arrive at the correct noise-to-ground level. The level is the algebraic sum of the blue RANGE switch setting and the blue meter scale indication plus 40dB. For example, RANGE is set to 20dBm and the meter indicates +3dBm. The noise-to-ground level is $20 + (+3) + 40 = 63\text{dBm}$. Some telephone company operating procedures disregard the 40dB correction factor in which case the noise-to-ground level would be $20 + 3 = 23\text{dBm}$.

3-38. The Nm and Ng indications can be used to compute the balance of a facility since balance is defined as the degree of rejection of longitudinal signals. The degree of balance in dB where the major part of noise-metallic is due to noise-to-ground, is given by the equation, Balance in dB = Nm - Ng. For example, if the noise-metallic level of a circuit is +26dBm and the noise-to-ground of the same circuit is +90dBmC, the balance in dB is $(+26) - (+90) = 64\text{dB}$. In the case mentioned above where the 40dB correction factor is neglected, the balance in dB = (Nm) (Ng + 40).

3-39. Other general purpose uses of the 3555B are volume and crosstalk measurements. The ballistic characteristics of the set make it approximately correct for VU measurements. The RANGE switch should be adjusted until the meter pointer fluctuations are on-scale and should be observed for the maximum of the frequently occurring peaks, disregarding the occasional high peaks. The meter indication in dBm is equal to VU (volume units.)

Model 3555B

3-40. Crosstalk measurements involve low level measurements and part of the meter indication may be 3-8 Model 3555B caused by noise in addition to crosstalk. The general technique is to measure with crosstalk and noise present and then measure noise alone. A correction factor must then be applied and can be found in Table 3-2.

3-41. RECORDER COMPATIBILITY.

3-42. If an external recorder is to be used to monitor the dc output of the 3555B, the Recorder Compatibility graph, Figure 3-4 should be consulted to determine if your particular recorder can be used. Recorders with input characteristics that fall below the compatibility area can be used provided a suitable resistor is used between the 3555B dc output and the recorder input.

3-43. To choose the value of this resistance, simply follow the line designating the full scale current of your recorder, horizontally until it intersects the top line in the Recorder Compatibility graph. From this intersection follow the vertical line to find the total impedance RT required for full scale deflection (see Figure 3-3). The input impedance of the recorder should be subtracted from this value RT to determine the value of R1. For example, assume that your particular recorder has an input impedance of 2000 ohms with a full scale sensitivity of 20uA. Follow the 20uA line to the right until it intersects the top line at 48 kilohms. The value of R1 will then be $48\text{ kilohms} - 2\text{ kilohms input impedance} = 46\text{ kilohms}$.

3-44. Recorders with input characteristics that fall above the compatibility area in Figure 3-4 cannot be used to monitor the 3555B dc output since full scale deflection of the recorder cannot be accomplished by the 3555B.

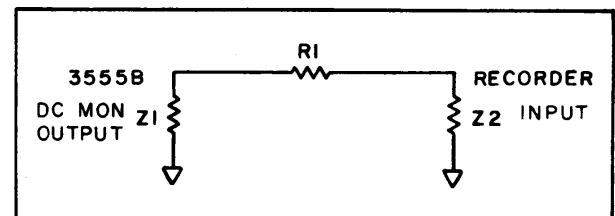

Figure 3-3. Impedance Matching 3555B to Recorder

3-45. APPLICATIONS.

3-46. Sometimes it is necessary to transmit or send a tone on a line and then measure the received signal coming back on the same line. Rather than change connections back and forth between the 3555B and 236A Oscillator when changing from SEND to RECEIVE and thus take a chance on dropping the line, it is much more convenient to make one set of connections and then select SEND or RECEIVE by means of a switch. Refer to Figure 3-5.

3-47. By utilizing the test set-up shown in Figure 3-5, send and receive can be accomplished with a minimum number of operations. To dial, set both function switches to DIAL and dial the desired line on the butt-in. To send, change the

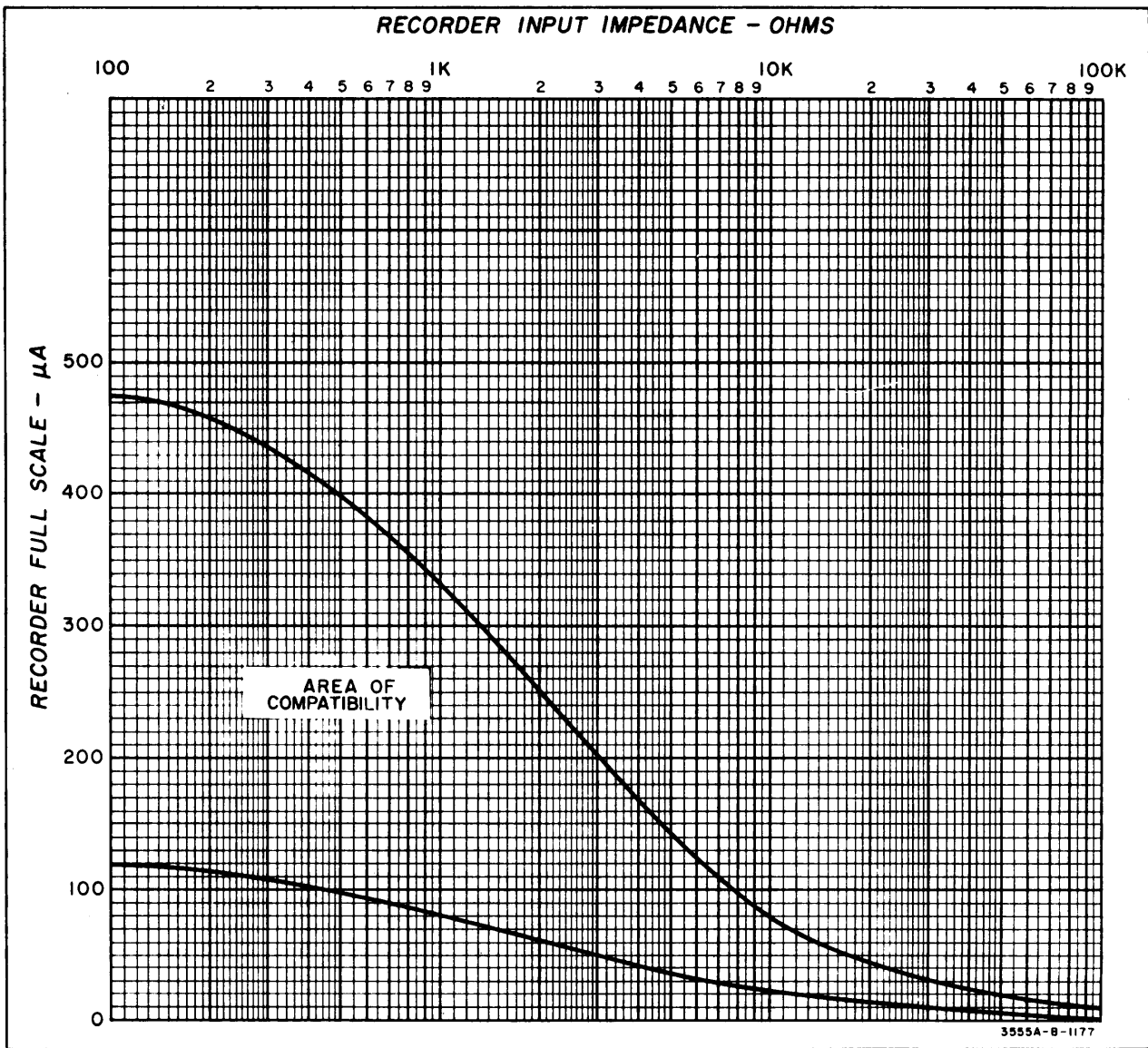

Figure 3-4. Recorder Compatibility Chart

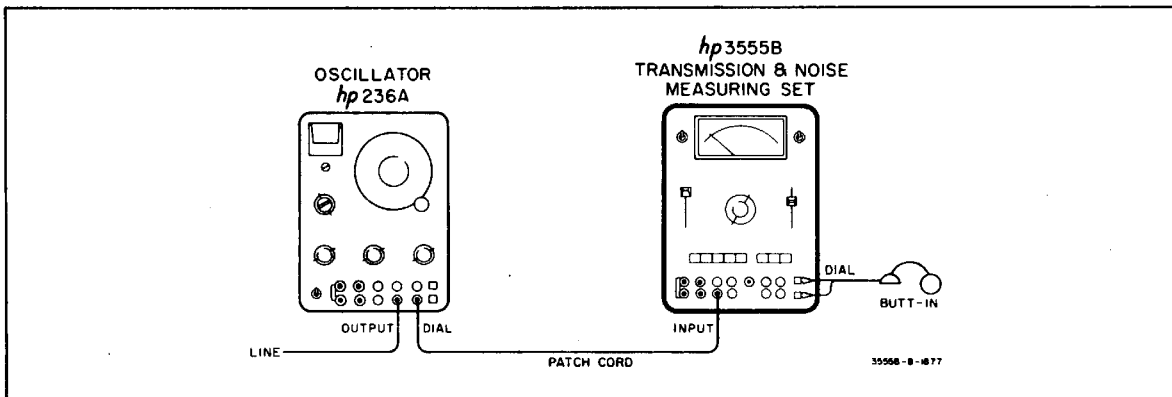

Figure 3-5. Simplified Send/Receive Test Set-up

236A FUNCTION switch to 600 HOLD or 900 HOLD, depending on the impedance required. To receive a tone, set the 3555B FUNCTION switch to either 600 HOLD or 900 HOLD (whichever is appropriate) and change the 236A FUNCTION switch to DIAL. To send again, simply change the 236A to 600 HOLD or 900 HOLD. If holding is not required or dialing is not required, simply select the impedance and switch back and forth on the 236A FUNCTION switch.

3-48. TRANSMISSION LOSS MEASUREMENTS.

3-49. Transmission loss is defined as the ratio of power from a transmission line by a receiving terminal to the power available from the sending equipment and is dependent on three factors; power dissipated by the dc resistance of the line, power losses because of impedance mismatch, power transferred to other circuits by inductive or capacitive coupling. (See Figure 3-6).

3-50. These factors are difficult to measure separately. Their sum, however, is relatively easy to measure with the -hp- 236A/3555B combination.

3-51. Figure 3-6 shows a typical transmission loss measurement setup. The oscillator is adjusted for a reference level and the signal is measured at the other end of the line with a level meter. Loss measurements are usually made at various frequencies to determine the response of the line.

3-52. Ideally the man at each end of the line will have both an oscillator and a Transmission Measuring Set (TMS) so that the loss can be measured in both directions, If the line that is being tested passes through central office switching equipment, the oscillator or TMS at the remote end is placed in the DIAL mode and the lineman's handset connected to the DIAL posts, permitting the repairman to bypass the instrument circuitry and dial his test board at the central office. Tests are then made in the 600 or 900 ohm HOLD positions, which provide a dc path to hold the switching relays.

3-53. CROSSTALK MEASUREMENTS.

3-54. Crosstalk is interference on a transmission line caused by inductive and capacitive coupling between pairs of transmission lines in close proximity. Crosstalk can be classified as near-end and far-end. Far-end crosstalk is interference at the end of the transmission line opposite the , signal source while near-end crosstalk is interference detected at the same end of the line as the signal source.

Table 3-2. Crosstalk Correction Factor

(Crosstalk + Noise) in dB Minus Noise Alone in dB	dB Correction Factor Crosstalk in dB = (Crosstalk + Noise) Minus Correction Factor
1	7
2	4
3	3
4 to 5	2
6 to 8	1
9 and above	0

3-55. Since different frequency bands are used for each direction of transmission on two wire carrier systems, near-end crosstalk cannot be detected. The situation is quite different, however, for far-end crosstalk since it is in the same frequency band as the desired signal and can be detected.

3-56. Referring to Figure 3-7, one line is designated A-B and the other designated C-D with A and C representing the near-end of one of the pairs, and band D representing the far-end of the other pair. First measure the transmission loss between A and B. Then measure the transmission loss from A to D. The crosstalk coupling loss in dBx is the difference in the reading from A to B and the reading from A to D.

3-57. IDENTIFYING NOISE CHARACTERISTICS.

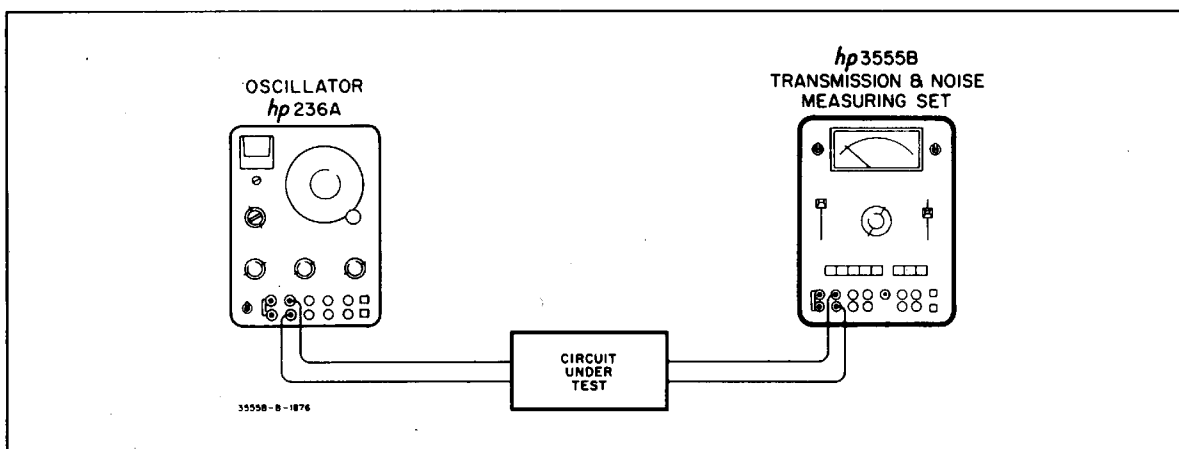

Figure 3-6. Typical Test Setup for Measuring Insertion Loss

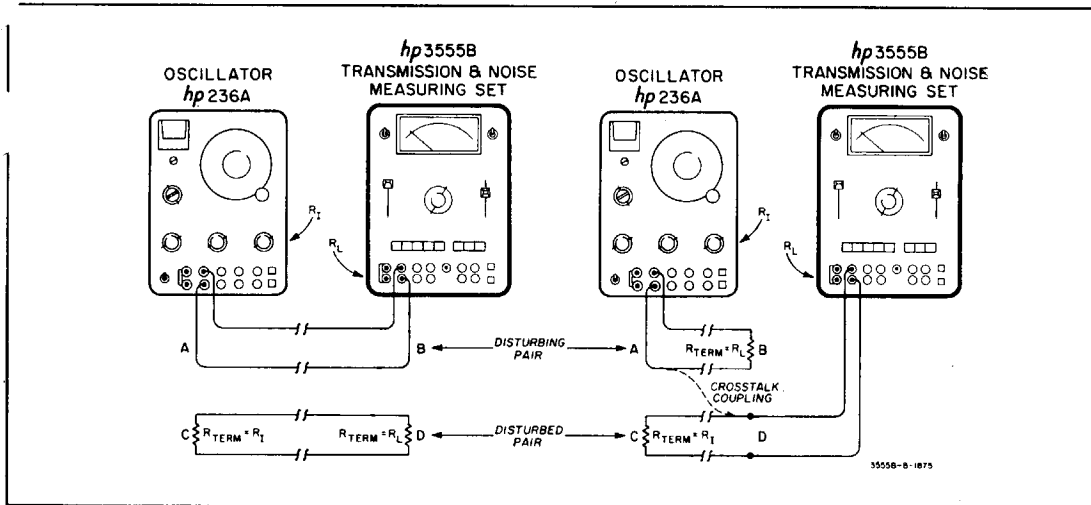

Figure 3-7. Test Setup for Measuring Crosstalk Coupling Loss

3-58. Normally, a frequency selective voltmeter is used to identify the characteristics of transmission line interference in order to trace it down to its origin and apply the appropriate corrective action. As an expedient for troubleshooting, there are several subjective measurements that the 236A/3555B can make to help identify the interference characteristics.

3-59. Since power line noise is the most common nuisance, a quick check with the 3555B should be made first. By noting the difference in noise readings between the 3kHz FLAT and C-message weighted modes, an indication of line frequency disturbance can be ascertained if the 3kHz flat mode shows a substantially higher reading.

3-60. As a further aid in identifying noise, the lineman's handset can be connected to the AC MONITOR terminals and an aural analysis made. Although the handset will not respond to 60Hz, line interference is usually very rich in odd harmonics and 180Hz can easily be identified. This test also helps to identify "babble" and other audio frequency interference.

3-61. Vagrant noise, such as atmospheric noise, can be analyzed by connecting a strip chart recorder to the DC MONITOR terminals. Long-term seasonal and temperature effects can also be measured very conveniently with a recorder.

3-62. Frequency of strong interfering periodic signals, such as radio transmitters, can be roughly determined with the 236A and 3555B. The 236A is connected to one end of the line and the 3555B to the remote end, as with transmission loss measurements. The oscillator output is increased until the test meter barely indicates a signal above the noise. The oscillator frequency is then changed very slowly while the repairman observes the 3555B for a beat. By tuning for a beat, the frequency of the interfering signal can be read directly off the

oscillator frequency dial to an accuracy of approximately $\pm 3\%$. In practice, this measurement would probably be made using a "loop around" technique. The oscillator would be connected to a quiet line at the remote location and this line would be tied to the noisy line back at the central office. This permits one man to operate both the oscillator and the test meter.

3-63. When a current flows through a conductor, it sets up two distinct fields around the conductor - - the electrostatic (capacitive) field and the magnetic (inductive) field. Both are capable of inducing longitudinal voltages in adjacent conductors, and both increase in proportion to the power and frequency of the current from which they result. They differ greatly, however, in how they affect nearby circuits. The voltage resulting from magnetic induction varies inversely-with the impedance of the line. That is, the higher the line impedance, the less voltage that can be induced by a magnetic field. Capacitively coupled voltage, on the other hand, increases in direct proportion to line impedance-- the higher the impedance, the greater the capacitive coupling. By means of a simple test, it is possible to identify the coupling between two lines, as shown in Figure 3-8. Since induced voltages are inversely proportional to line impedance, the voltage coupled from pair A into pair B (Figure 3-8a) will increase as the impedance is lowered (i.e., shorted). Conversely, since capacitively coupled voltages are directly proportional to impedance, the coupled voltage in Figure 3-8b would increase as the impedance is increased (i.e., open circuited). Both tests in Figure 3-8 should be performed to correlate the result.

3-64. MEASUREMENTS IN DBC.

3-65. The term dBC means dB Collins and is defined as

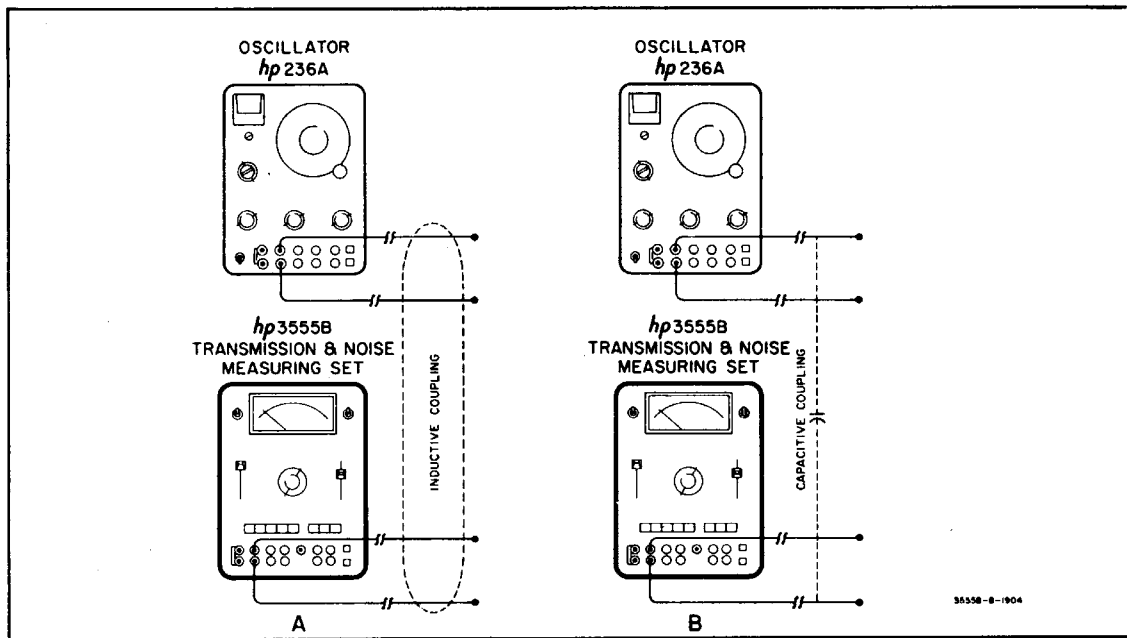

Figure 3-8. Simple Test for Inductive and Capacitive Coupling

0dBc = 0.775V across any impedance as read on an -hp- Model 400D AC Vacuum Tube Voltmeter. Thus, the dBc is strictly a relative term.

3-66. Measurements can easily be made in dBc. by utilizing the Model 3555B Telephone Test Meter. To make these measurements, set FUNCTION to 600 and the INPUT switch to TMS BRDG. Any termination required other than 600 ohms must be provided externally and connected across the two binding posts T and R. Termination can also be made using a patch cord and any one of the other INPUT jacks since all INPUT jacks are connected in parallel. If a 600 ohm termination is to be used, the internal termination can be utilized by placing the INPUT switch to the TMS TERM position.

3-67. MEASUREMENT PROCEDURES.

3-68. Tables 3-3 through 3-8 list the step by step procedures for measuring levels and noise balance, recorder calibration and transmission loss using the 3555B. For a more detailed discussion on level and noise measurements refer to paragraphs 3-12 through 3-47.

3-69. 150 BAL CONVERSION.

3-70. The 3555B comes equipped with all the necessary parts for converting the 135 BAL function to a 150 BAL function. The following is a simplified procedure for making the modification.

- a. Remove the set from the case and remove the FUNCTION board. Clip the shorting wire from across A1R17 (see Figure 7-2) and reinstall the FUNCTION board. Leave the set out of the case.
- b. Set the 3555B controls as follows:
 RANGE..... 0dBm
 FUNCTION..... 135 BAL
 INPUT TMS TERM
- c. Remove the 150 BAL decal from the envelope supplied with the set. Remove the backing from the decal and place it over the 135 BAL function pushbutton.
- d. Connect a 150 ohm balanced source to the input of the 3555B at a level of 0dBm (387mV rms) at a frequency of 1kHz. Turn the 3555B ON and adjust A3R24 (Figure 7-3) for 0dBm indication on the 3555B meter.
- e. Reinstall the set in its case.

Table 3-3. Level Measurement

STEP	PROCEDURE														
1.	Turn the 3555B/ON and depress the DIAL/BAT pushbutton. The meter should indicate in the green BAT GOOD area. If it does not, replace the battery or check the power source before attempting to make any measurements. The battery test operates for internal battery, office battery or ac power source.														
2.	Select either TMS BRDG or TMS TERM, depending on the measurement being made. The weighting filters are not in the circuit at this time.														
3.	Select the impedance (FUNCTION pushbutton) to match the circuit to be tested. Select either 900 BAL or 600 BAL (VF/Nm) for frequencies between 20Hz and 20kHz. Select 600 BAL or 135 BAL (CARRIER) for balanced measurements between 1 kHz and 600kHz. Select 75 UNBAL for 75 ohm unbalanced measurements between 30Hz and 3MHz.														
4.	Set the RANGE switch to +30dBm. Set the RESPONSE switch to DAMP.														
5.	Connect the set to the line using a suitable patch cord. For balanced measurements use a cord having a 309 or 310 single plug, a 241 dual plug or banana plugs, bare wires or clip leads. For unbalanced carrier measurements (75 ohm only) use a cord having a 358 plug.														
<p>NOTE Carrier measurements are limited to the -50dBm RANGE thru the +10dBm RANGE.</p>															
6.	Down range the RANGE switch for an on-scale indication. Level is equal to the algebraic sum of the black RANGE setting plus the black meter scale indication.														
<p>EXAMPLES:</p> <table style="margin-left: 40px;"> <tr> <td>RANGE =</td> <td>-50dBm</td> </tr> <tr> <td>METER =</td> <td><u>+1dBm</u></td> </tr> <tr> <td>LEVEL =</td> <td>-49dBm</td> </tr> <tr> <td colspan="2"> </td> </tr> <tr> <td>RANGE =</td> <td>+20dBm</td> </tr> <tr> <td>METER =</td> <td><u>-4dBm</u></td> </tr> <tr> <td>LEVEL =</td> <td>+16dBm</td> </tr> </table>		RANGE =	-50dBm	METER =	<u>+1dBm</u>	LEVEL =	-49dBm			RANGE =	+20dBm	METER =	<u>-4dBm</u>	LEVEL =	+16dBm
RANGE =	-50dBm														
METER =	<u>+1dBm</u>														
LEVEL =	-49dBm														
RANGE =	+20dBm														
METER =	<u>-4dBm</u>														
LEVEL =	+16dBm														

Table 3-4. Noise Metallic Measurements

STEP	PROCEDURE									
1.	Turn the POWER switch to ON and depress the DIAL/BAT pushbutton. The meter should indicate in the green BAT GOOD area. If it does not replace the battery or check the power source. The battery test operates on internal battery, office battery or ac power source.									
2.	Select either NOISE TERM or NOISE BRDG, depending on the measurement being made.									
3.	Select the impedance to match the circuit to be tested using the FUNCTION pushbuttons. The 900 BAL VF/Nm pushbuttons only should be used for noise metallic measurements in the frequency range of 20Hz to 20kHz. The HOLD function can be used in NOISE TERM if desired.									
4.	Select the appropriate weighting filters using the NOISE WTG switch.									
5.	Set the RANGE switch to 110dBrn.									
6.	Connect the set to the circuit to be tested using a suitable patch cord and down range for an on-scale indication.									
7.	Observe the meter fluctuations for two or three minutes and take a reading where the meter pointer appears to be most of the time, disregarding any occasional peaks.									
<p>NOTE For rapidly fluctuating noises such as atmospheric noise or switching noise, operate the RESPONSE switch to DAMP and read the level of the most frequently occurring peaks.</p>										
8.	Noise level is equal to the sum of the blue RANGE switch setting in dBrn and the indication on the blue meter scale in dBrn.									
<p>EXAMPLE:</p> <table style="margin-left: 40px;"> <tr> <td>RANGE</td> <td>=</td> <td>40dBrn</td> </tr> <tr> <td>METER</td> <td>=</td> <td><u>+5dBrn</u></td> </tr> <tr> <td>NOISE LEVEL</td> <td>=</td> <td>+45dBrn</td> </tr> </table>		RANGE	=	40dBrn	METER	=	<u>+5dBrn</u>	NOISE LEVEL	=	+45dBrn
RANGE	=	40dBrn								
METER	=	<u>+5dBrn</u>								
NOISE LEVEL	=	+45dBrn								

Table 3-5. Noise-to-Ground Measurements

STEP	PROCEDURE
1.	Turn the 3555B POWER switch to ON and depress the DIAL/BAT pushbutton. The meter should indicate in the green BAT GOOD area. If it does not replace the battery or check the power source. The battery test operates for internal battery, office battery or ac power source.
2.	Set the INPUT switch to NOISE BRDG.
3.	Select the appropriate weighting filter using the NOISE WTG switch.
4.	Set the RANGE switch to 110dBm.
5.	Depress the NG pushbutton and connect the set to the circuit to be tested. Down range for an on-scale indication.
<p>————— NOTE —————</p> <p>Dial and talk may be accomplished on the metallic circuit and the connection held by depressing the HOLD pushbutton.</p>	

Table 3-6. Balance Measurement

STEP	PROCEDURE
1.	Perform the Noise-to-ground measurement as described in Table 3-5.
2.	Perform the Noise Metallic measurements as described in Table 3-4.
3.	Compute the line balance in dB using the results of the above checks.
<p>Balance (dB) = Nm - NG</p>	
<p>EXAMPLE:</p>	
<p>Noise-to-ground = +26dBm Noise Metallic = (-)+90dBm Balance in dB = -64dBm</p>	
<p>————— NOTE —————</p> <p>The noise-to-ground measurement above includes the 40dB correction factor.</p>	

Table 3-7. Recorder Calibration

STEP	PROCEDURE
1.	Determine the input impedance and full scale sensitivity of your recorder and refer to paragraph 3-41 and Figure 3-4 to determine if your recorder is suitable for use with this set. The dc voltage supplied by the DC MON 310 jack will drive a dc potentiometric recorder requiring 1V or a dc galvanometric recorder requiring 500uA.
2.	Connect an input voltage to the set and adjust the RANGE switch until a near full-scale indication is observed on the meter.
3.	Connect the recorder plug with the tip negative, to the DC MON jack and adjust the input level until the meter indicates 0dBm. Mark this point on the recorder paper which should be near full scale.
4.	Decrease the input level to the set until the meter indicates -1dBm. Mark this point on the recorder paper. Continue this procedure until every major dBm division on the meter has been calibrated on the recorder paper.
5.	The actual level to the set as indicated on the recorder is equal to the algebraic sum of the RANGE setting and recorder indication.

Table 3-8. Transmission Loss Measurement

STEP	PROCEDURE
1.	For a transmission loss measurement to be meaningful, it should first be determined if there are any extraneous signals present that will affect your measurement. To do this, connect the measuring set to the circuit and determine if interfering signals are present. Levels below 60dB can, in most cases, be ignored. A butt-in can be connected to the AC MON jacks to aid in determining the interfering source.
2.	Establish a connection like the ones shown in Figure 3-6.
3.	Adjust the oscillator output level for 0dBm. Measure the level at the receiving end and record this level.
4.	Insertion loss is equal to the difference between the sending level and the receiving level, ignoring any extraneous signals.
<p>EXAMPLE:</p>	
<p>Sending level = 0dBm Receiving level = (-)- 20dBm Insertion loss = 20dB</p>	

**SECTION IV
THEORY OF OPERATION**

4-1. INTRODUCTION.

4-2. The Model 3555B Transmission and Noise Measuring Set is a special measuring set designed for uses in testing telecommunications equipment. Inputs between -90dBm and +30dBm full scale can be selected in twelve ranges for level measurements and correspond to the black markings on the meter scale and the RANGE switch. Noise measurements between 0dBm and +120dBm full scale can be made, selectable in twelve ranges and corresponds to the blue markings on the meter scale and RANGE switch. When measuring rapidly fluctuating noises, a damping circuit can be inserted by the RESPONSE switch.

4-3. Impedances of 75, 135 and 600 ohms, terminated or bridging can be selected for carrier level measurements. The 135 and 600 ohm functions can be either balanced or unbalanced while the 75 ohm function is unbalanced only. For voice frequencies, impedances of 600 and 900 ohms are provided. These impedances are selectable by the pushbutton FUNCTION switch and can be terminated or bridging, balanced or unbalanced.

4-4. A noise-to-ground (Ng) function is included to permit measurement of longitudinal noise. When the Ng pushbutton is depressed, a 40dB attenuator is placed across the INPUT terminals.

4-5. The HOLD function places a high inductance holding coil across the INPUT terminals to simulate an off-hook condition while measurements are being made. The HOLD function is not operative on any of the carrier functions.

4-6. A variety of INPUT and DIAL jacks are provided which accept Western Electric type 241 and 289 dual plugs, 309, 310, 347, and 358 single plugs, dual banana plugs, clip leads and bare wires.

4-7. BLOCK DIAGRAM DESCRIPTION.

4-8. Figure 4-1 illustrates a simplified block diagram of the Model 3555B Transmission and Noise Measuring

Set. Refer to this figure for the following block diagram description.

4-9. The input signal is first applied to the FUNCTION switch where the input circuitry is set up to accommodate the type of measurement being made. For voice frequencies, impedances of 900 ohms or 600 ohms can be selected, bridged or terminated. Voice frequencies are then applied to a transformer with a frequency range of 20Hz to 20kHz. The HOLD function places a high inductance bridge across the INPUT terminals to simulate an off-hook condition. For carrier frequencies impedances of 600 ohms, and 135 ohms can be selected, terminated or bridged, balanced or unbalanced. Carrier frequencies at these impedances are applied to a transformer having a frequency range from 5kHz to 600kHz. For 75 ohm carrier frequencies an unbalanced input is provided. This input can be either terminated or bridged. HOLD is not possible on any of the carrier functions.

4-10. For longitudinal measurements, an Ng function is provided which places a 40dB attenuator across the INPUT terminals. The HOLD function bridges the input with a holding coil while measurements are being made. The output of the 40dB attenuator is always applied to the voice frequency transformer.

4-11. The DIAL/BAT function serves two functions. First it connects the DIAL/AC MON jacks to the INPUT jacks so that a handset can be used for dialing. Secondly, the meter is connected to the unregulated power supply so that the battery condition can be monitored.

4-12. After the signal is conditioned by the input circuitry it is coupled to the RANGE attenuator where the signal level is adjusted to provide the proper input for the Input Amplifier. The RANGE attenuator provides from 0dB to 80dB of attenuation. It also provides gain switching for the Input Amplifier.

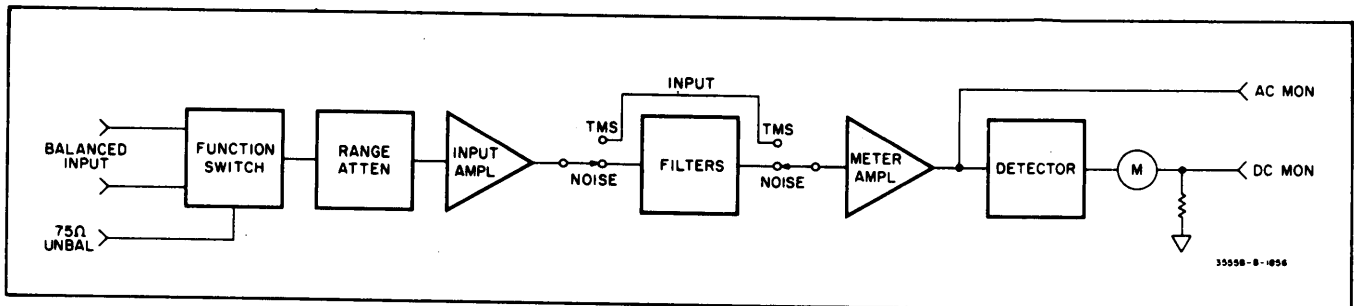

Figure 4-1. Simplified Block Diagram

4-13. The output of the Input Amplifier goes to the INPUT switch where noise filters are set up for selection by the NOISE WTG switch. In the NOISE position, either 3kHz FLAT weighting, C Message weighting, 15kHz FLAT weighting or PROGRAM weighting can be selected by the NOISE WTG switch. In the TMS position of the INPUT switch the filters are bypassed for transmission level measurements.

4-14. The output from the INPUT switch goes to the meter amplifier. This amplifier provides an ac signal to the DIAL/AC MON jacks so that a handset can be used to listen to the signal being measured. This is particularly useful in determining noise characters.

4-15. The detector circuit provides an equivalent rms detected voltage to drive the meter. The meter has shaped pole pieces to provide a linear meter scale both for dBm and dBrn.

4-16. DETAILED CIRCUIT DESCRIPTION.

4-17. The purpose of the function switch is to set up the input conditions to match the type of measurement being made. Impedances can be selected to match the lines to be tested and can be either bridged or terminated. Separate transformers are selected for voice frequency and carrier frequency measurements. A 40dB attenuator is bridged across the input terminals for longitudinal noise measurements when the Ng pushbutton is depressed. The HOLD function places a high inductance holding coil across the input terminals to simulate an off-hook condition. Each of these functions is described in detail in the following paragraphs.

- a. HOLD: When the HOLD pushbutton is depressed a high inductance coil LI is connected across the Model 3555B balanced INPUT terminals if the INPUT

switch is in the TERM position. A bridging HOLD is not possible. The TERM switch connects the two windings of L1 in series.

- b. DIAL BAT: (See Figure 4-2) The DIAL BA1 pushbutton serves two purposes. First it disconnects the meter from the detector and connects it to the unregulated power supply so that the battery voltage can be monitored. Secondly, the DIAL/AC MON jacks are disconnected from the amplifier ac output and connected to the INPUT jacks. This permits connecting the lineman's handset to the balanced line for the purpose of dialing.
- c. Ng: (See Figure 4-3) The Ng pushbutton connects a 40dB attenuator across the balanced input terminals for longitudinal measurements. This attenuator consists of A1R5 thru A1R8 and A1C1. The output is taken from the junction of A1C1 and A1R8. This output is referenced to ground and applied to the voice frequency transformer A1T2.
- d. 900 (Vf/Nm): The 900 function switch S4 selects terminating resistors A1R1 and A1R9 for 900 ohm terminations. The INPUT switch must be in _ the TERM position to complete the circuit for this termination. The 900 function switch also places a ground on the 900 ohm relay A3K1 which provides gain switching in the Input Amplifier so that the meter will indicate in dBm. The 900 ohm signal is applied to the voice frequency transformer A1T2. HOLD can be accomplished on this function.

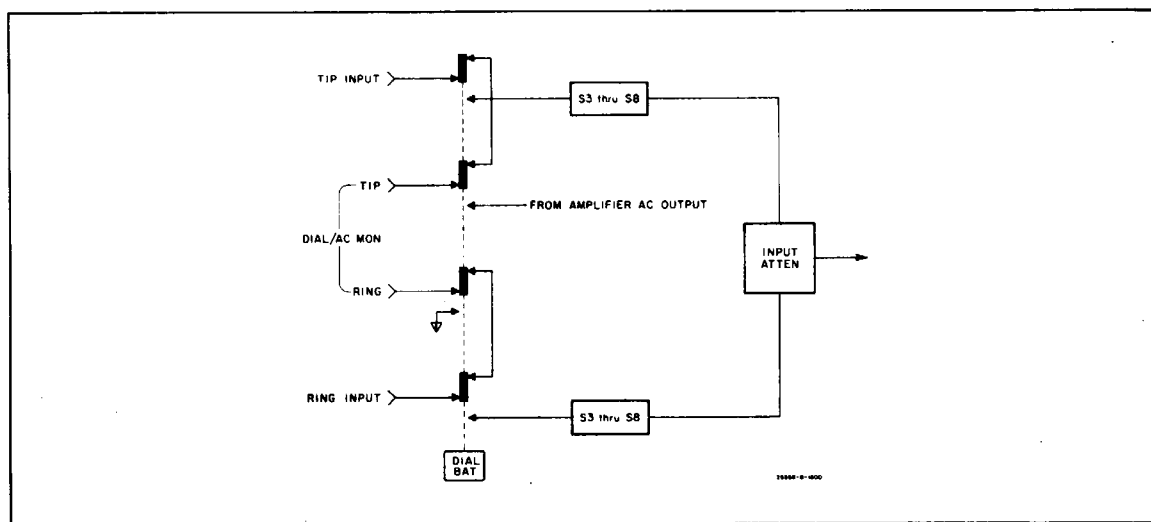

Figure 4-2. Simplified DIAL BAT Function

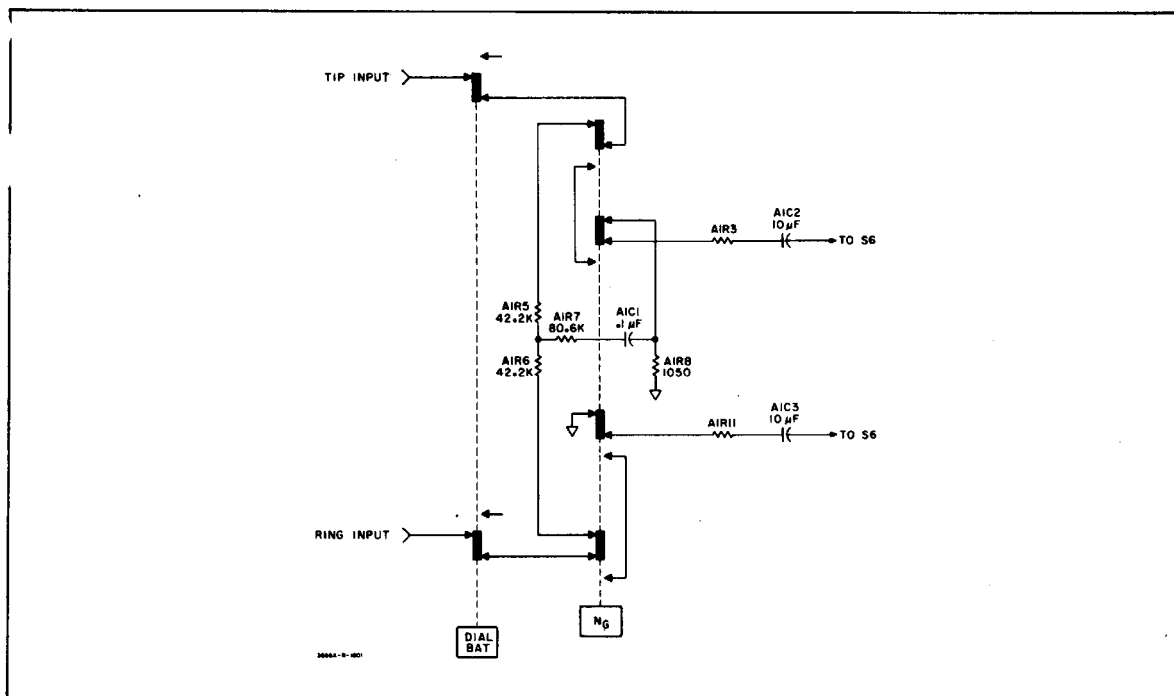

Figure 4-3. Simplified NG Function

- e. 600 (Vf/Nm): The 600 function switch S5 selects terminating resistors A1R2 and A1R10 for a 600 ohm termination. The INPUT switch completes the circuit for this termination. The 600 (Vf/Nm) signal is applied to T2. No gain switching is performed in this function since the set is normalized at 600 ohms HOLD can be accomplished on this function.
- f. 600 (Carrier): This function is identical to the 600 (Vf/Nm) function except that the signal is applied to A1T1 and HOLD cannot be accomplished on this function.
- g. 135 (Carrier): The 135 function is identical to the 600 (carrier) function except that the gain switching in the Input Amplifier is accomplished by one section of the 135 function switch S7.
- h. 75 UNBAL: The 75 UNBAL function bypasses the balanced input circuitry and transformer AIT1 and A1T2. Gain switching is performed by one section of this function switch. When the 75 UNBAL function is selected the output of the balanced circuitry is disconnected. A 75 ohm termination is provided thru the INPUT switch.

4-18. RANGE ATTENUATOR A2.

4-19. The RANGE attenuator adjusts the input signal to a suitable level for the Input Amplifier. This

attenuator is composed of four L pads, selectable in combinations to provide from 0dB to 80dB of attenuation. Two 30dB pads are selected by A2S1A and A2S1B, a 20dB pad is selected by A2S1C and a 10dB pad is selected by A2S1D. Another section of the RANGE attenuator switch provides gain switching for the Input Amplifier in the -80dBm, -70dBm and -60dBm positions. Refer to Table 4-1 for more detailed information on range attenuation and amplifier gain.

4-20. INPUT AMPLIFIER A3. (Schematic No. 2)

4-21. The purpose of the Input Amplifier is to provide the necessary gain at each setting of the RANGE switch and to provide the necessary gain at all impedances. This amplifier is normalized at 600 ohms and the following discussion is for the 600 ohm function.

4-22. Diodes A3CR1 thru A3CR4 serve as protection for the input amplifier. Signals greater than 7 volts peak-to-peak will be conducted to ground through these diodes. The gain of this amplifier is determined by the negative feedback from the emitter of A3Q5 to the base of A3Q2. This feedback is first determined by the ratio of A3R13 to the sum of A3R14 and A3R15. In position 1 of the RANGE switch (-80DBM) this feedback is further divided by the ratio of A3R11 to the sum of A3R25 and A3R26. In position 2 (-70DBM) of the RANGE switch the feedback is determined by the ratio of A3R11 to the sum of A2R13, A3R25 and A3R26. In position 3 (-60DBM) of the switch the feedback is determined by the ratio of A3R11 to the sum of A2R13, A2R14, A3R25 and A3R26.

Table 4-1. Range Attenuation and Amplifier Gain

RANGE Setting	RANGE Attenuation	ATTENUATOR PADS USED	Input Amplifier Gain
+30dBm	80dB	1,2,3	3.6dB
+20dBm	70dB	1,2,4	3.6dB
+10dBm	60dB	1,2	3.6dB
0dBm	50dB	2,3	3.6dB
-10dBm	40dB	2,4	3.6dB
-20dBm	30dB	2	3.6dB
-30dBm	20dB	3	3.6dB
-40dBm	10dB	4	3.6dB
-50dBm	0dB	0	3.6dB
-60dBm	0dB	0	13.6dB
-70dBm	0dB	0	23.6dB
-80dBm	0dB	0	33.6dB

In positions 4 thru 12 (-SODBM thru +30DBM), A3R11 is bypassed for maximum feedback. The gain of the amplifier in these nine positions is a constant 2.5dB. Potentiometer A3R26 is for calibration of the -80DBM range, 600 ohm function. Resistor A3R27 is used to maintain a charge on A3C22 to prevent transients when changing ranges.

4-23. In order that the meter always indicate in DBM regardless of the impedance selected, additional gain switching must be performed. When the 75 function is chosen, A3K2 energizes and places A3R16 in parallel with A3R14 and A3R15. This reduces the negative feedback (with respect to the 600 function) and increases the amplifier gain by 9dB. When the 135 function is selected, A3R22/R23/R24 are connected in series with A3R16. This combination is then in parallel with A3R14 and A3R15, reducing the feedback and increasing the amplifier gain by 6.4dB with respect to the 600 function. When the 900 function is depressed, A3R17, A3R19 and A3R20 are connected in parallel with A3R13, increasing the negative feedback and

reducing the amplifier gain by 1.7dB. Relays A3K1 thru A3K3 are controlled by the FUNCTION switch when any of the impedance functions except 600 are selected.

4-24. Transistors A3Q1 and A3Q2 form a differential amplifier. The signal is taken from the collector of A3Q1, amplified by A3Q4 and A3Q5 with A3Q5 providing feedback to the base of A3Q2. Transistor A3Q3 provides isolation between A3Q2 and A3Q4 to prevent undesired feedback. This results in a greater bandwidth than could be achieved without its use. The output signal is coupled through A3R17 and A3C10 to the INPUT switch.

4-25. FILTERS. (Schematic No. 3)

4-26. The 3555B contains a 3kHz FLAT weighting filter, a C MSG weighting filter, a PROG weighting filter and a 15kHz FLAT weighting filter. These active filters consist of five amplifiers with controlled feedback for waveshaping. They are used in combinations to form each of the filters (refer to Figure 7-1). Since all of these amplifiers are

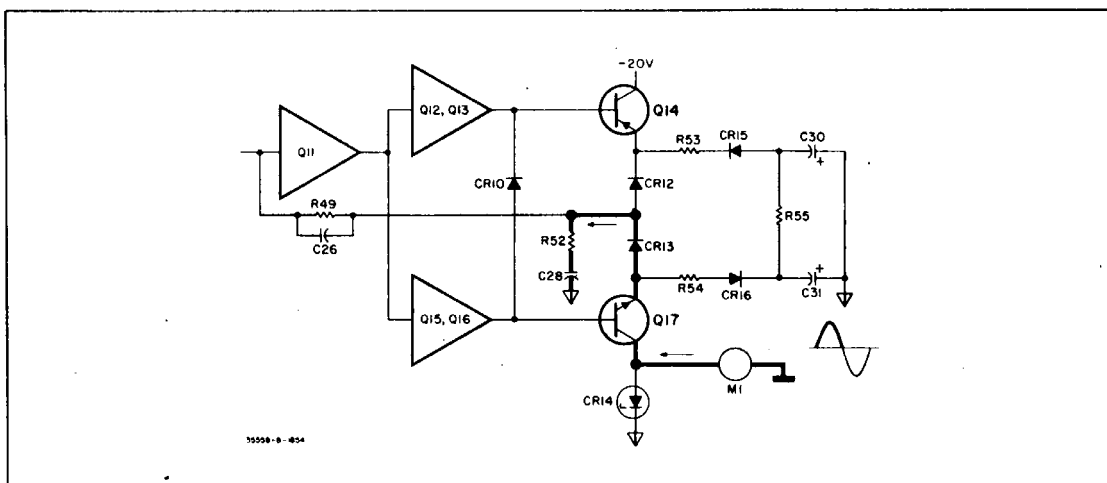

Figure 4-4. Simplified Average Detection

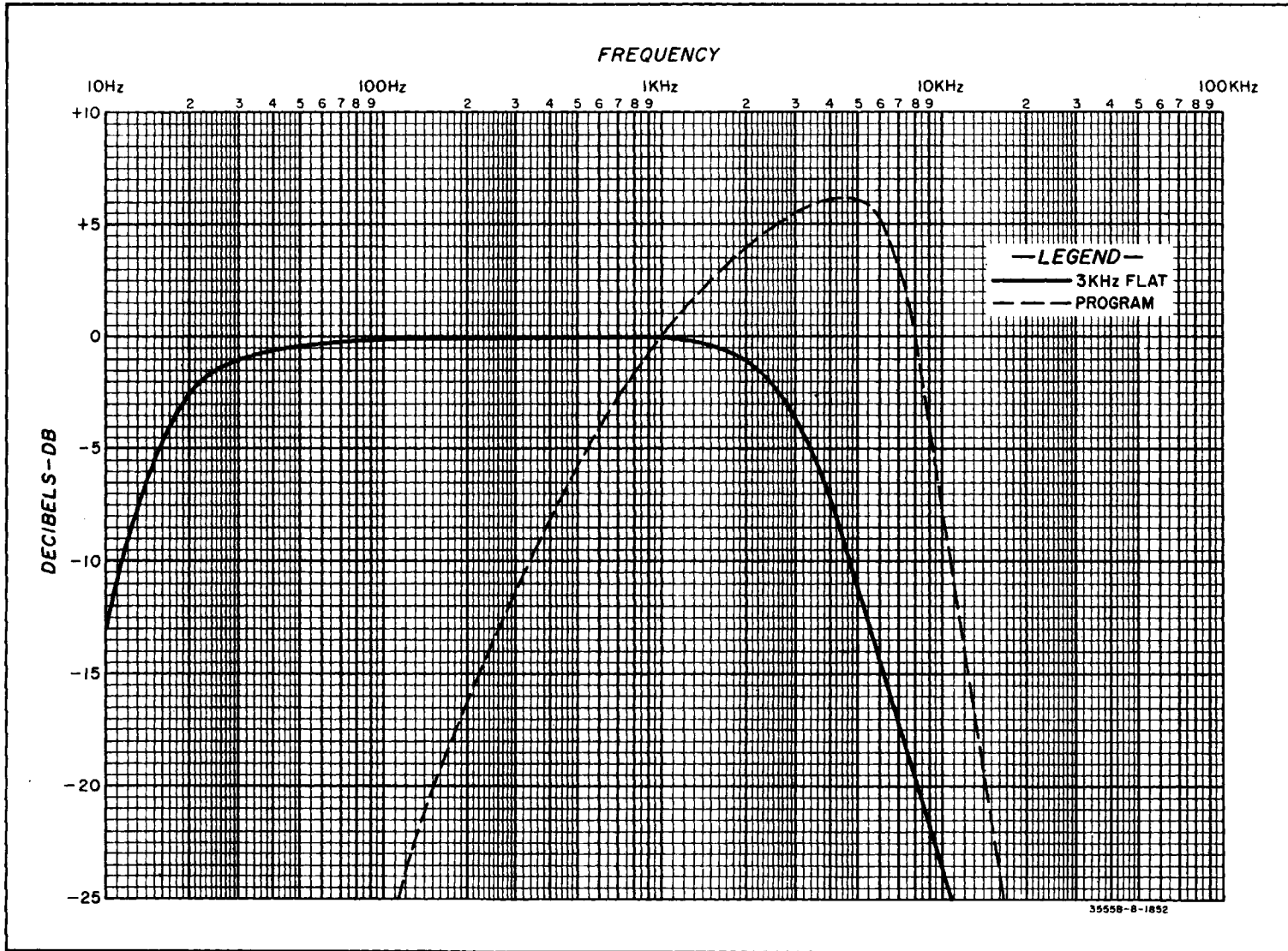

Figure 4-5. 3kHz FLAT and Program Weighting Curves

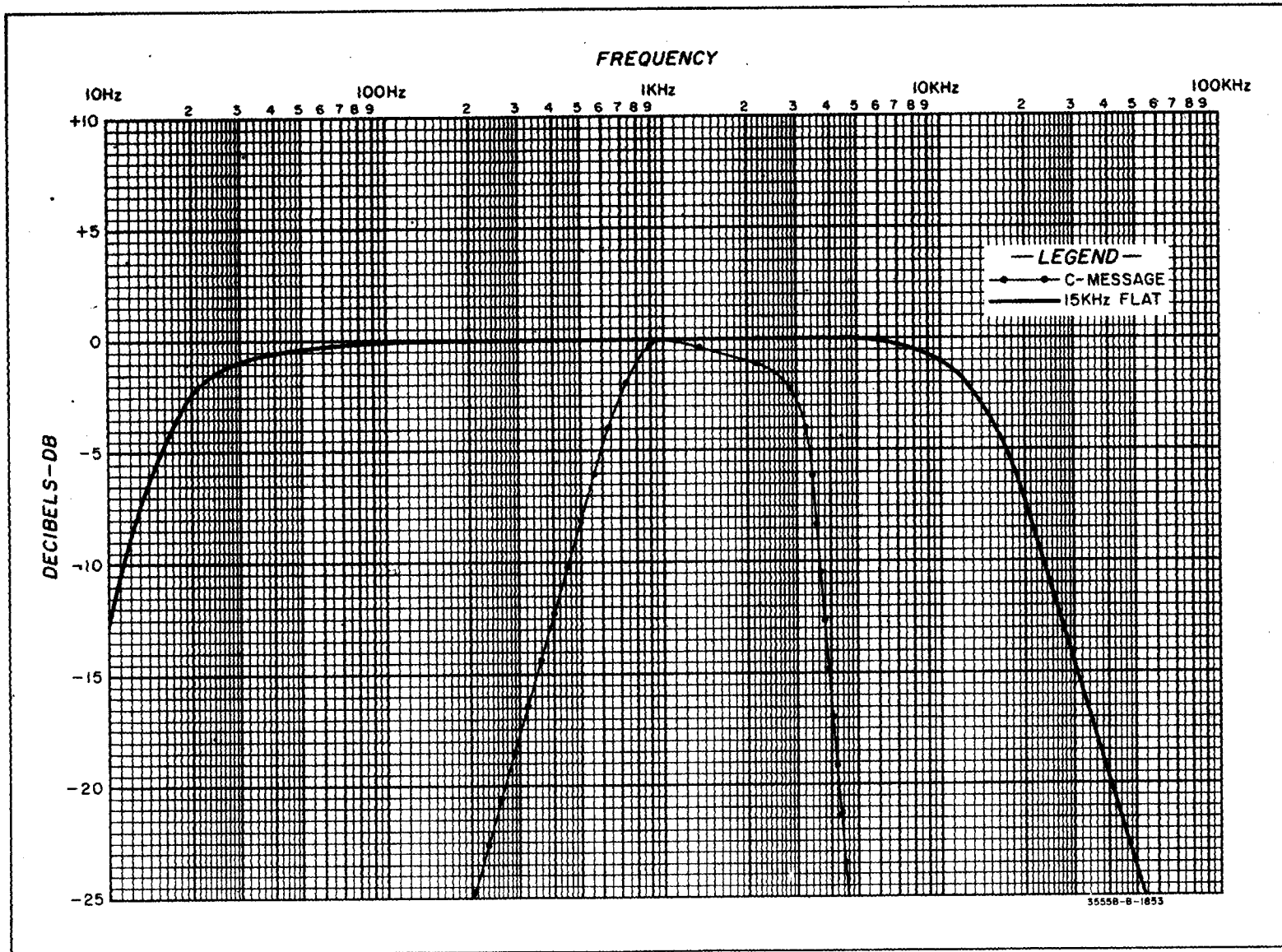

Figure 4-6. C-MSG and 15KHz FLAT Weighting Curves

identical in operation, only the first will be discussed in detail.

4-27. Referring to Figure 7-4, the signal is applied to the assembly through pin 22. If C MSG is selected the signal is first attenuated by A4R1, A4R2 and A4R3A. Potentiometer A4R3A is for C MSG level adjustment for 0dB at 1kHz. The signal is then applied to the first in a series of amplifiers. The first amplifier consists of A4Q1 through A4Q4. Differential amplifier A4Q1 and A4Q2 amplifies the signal and applies it to A4Q3 and A4Q4. The emitter circuit of A4Q4 provides two feedback signals, positive feedback through A4R8 and A4C4 to the base of A4Q1 and negative feedback to the base of A4Q2. The gain of this amplifier is controlled by the ratio of the value of A4R10 to the value of A4R9. For example, increasing the value of A4R9 would increase the negative feedback and reduce the amplifier gain. Gain can be calculated by the equation:

$$\text{Gain} = 1 + \frac{A4R10}{A4R9}$$

Positive feedback to the base of A4Q1 determines the frequency response of this amplifier and is controlled by the value of A4C4 and A4R8. All five of the amplifiers are used in C Message weighting.

4-28. The Program weighting filter utilizes only amplifiers No. 2 and No. 3 as shown in Figure 7-1. These amplifiers are identical to the one described in the preceding paragraph except for the value of the positive feedback utilized for shaping and the negative feedback used for gain control. This negative feedback is modified by resistance in the feedback divider at the base of A4Q12. Transistors A4Q5 and A4Q6 provide additional gain required for Program weighting. Potentiometer A4R3B is used for PROG level adjustment at 1kHz.

4-29. The 3kHz FLAT and 15kHz FLAT weighting filters utilize only amplifier as indicated in Figure 7-1. The only difference between these two active filters is in the positive feedback used for shaping and in the negative feedback used for gain. The negative feedback is altered by adding resistance to the feedback divider at the base of A4Q12.

4-30. METER AMPLIFIER. (Schematic No. 4)

4-31. The meter amplifier consists of A3Q6 through A3Q10. The signal is first amplified by differential amplifier A3Q6 and A3Q7. The signal is taken from the collector of A3Q6 and then amplified by A3Q9 and A3Q10. Transistor A3Q8 provides isolation between A3Q7 and A3Q9 to prevent undesired feedback. Two signals are taken from A3Q10. The collector circuit supplies a signal to the DIAL/AC MON jacks for the purpose of listening to the measured signal. The emitter circuit of A2Q10 provides a drive signal for the detector circuit.

4-32. DETECTOR. (Schematic No. 4)

4-33. The detector is a class B rms detector which combines the features of an average detector and a peak detector. When the average detected signals and the peak detected signals are combined in the proper proportion an equivalent rms response is produced.

4-34. First consider the average detection in this circuit. (See Figure 7-5). Transistors A3Q12-A3Q13 and A3Q15-A3Q16 are functionally symmetrical. This means that A3Q14 and A3Q17 are driven by the same signal. When the signal at the base of A3Q17 and A3Q14 goes negative, A3Q14 turns on and A3Q17 turns off. No current will flow through the meter. On the positive half cycle A3Q14 turns off and A3Q17 turns on. The current paths for the average detector are shown in Figure 4-4.

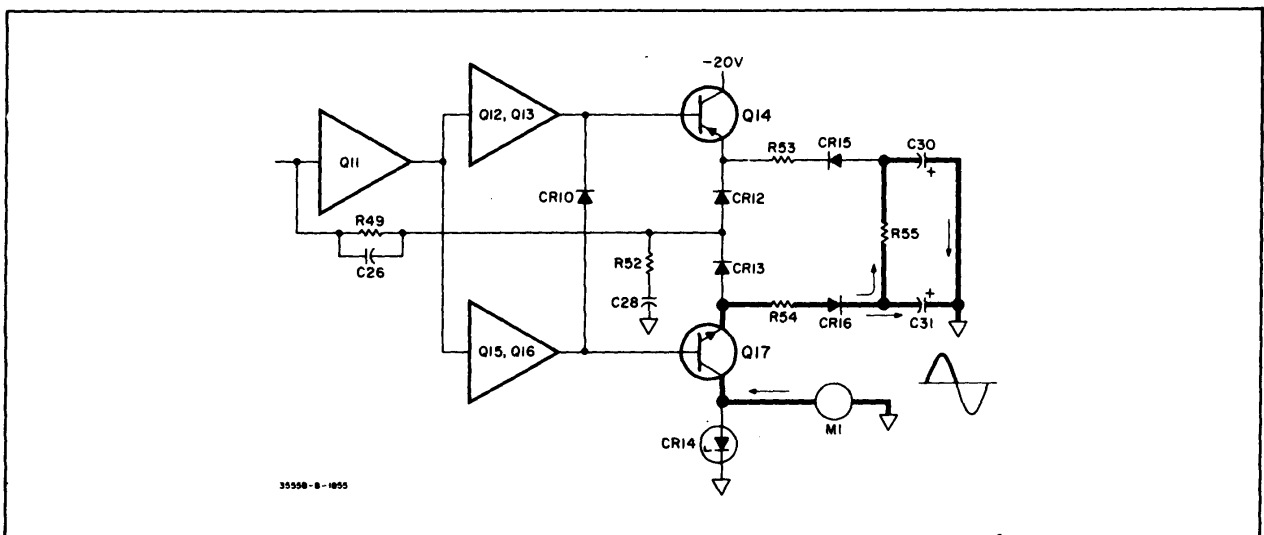

Figure 4-7. Simplified Peak Detection

4-35. Now consider the peak detection. (See Figure 7-5) When A3Q14 is turned on and A3Q17 is turned off, no current flows through the meter from the peak detector. When A3Q14 is turned off and A3Q17 is turned on, the current path is as shown by the heavy lines in Figure 4-7. Diodes A3CR12 and A3CR13 are included to offset the junction drop of A3CR15 and A3CR16 respectively.

4-36. When the average detection and the peak detector are combined in the proper proportion, an equivalent rms response is produced. The advantage of this type of rms detection is fast response.

4-37. POWER SUPPLY AND SERIES REGULATOR (Schematic No. 4)

4-38. The 3555B can be operated from 115V or 230V ac, the internal 48V dry cell battery or from a central office battery (tip negative). When operating from an ac source power is applied through transformer T1 and the AC/BAT switch S1 to the rectifier CR1. This rectified

voltage is filtered by C2 before being applied to the series regulator through J2, S3, CR1 and cable W1.

4-39. The regulator is of the conventional series type with A3Q19 acting as the sensing element and A3CR20 as the reference. Changes in the output level are amplified by differential amplifier A3Q18 and A3Q19. The output of the differential amplifier is amplified by A3Q20 and applied to A3Q21 which controls the conduction of the series transistor A3Q22. The output of this series regulator is held at - 20 volts ± 1 volt. The maximum ac ripple and noise on the output voltage is 200 μ V rms.

4-40. It should be noted that when operating the set from either the battery or from an ac source, capacitor C2 will always be charged whether the set is turned on or not. Caution should be exercised when servicing the power supply.

**SECTION V
MAINTENANCE**

5-1. INTROOUCTION.

5-2. This section of the manual contains information necessary in the maintenance of the -hp- Model 3555B Transmission and Noise Measuring Set. Included are performance checks, adjustment and calibration procedures and troubleshooting.

5-3. The test equipment needed to properly maintain and service the Model 3555B is listed in Table 5-1. Included in Table 5-1 is the equipment to be used, required specifications and recommended model. If the recommended model is not available other equipments

can be substituted provided they meet the required specifications.

5-4. FACTORY SELECTED VALUES.

5-5. Factory selected values are denoted on the schematic diagrams by an asterisk. The nominal value is shown. The value in your instrument may be different or the part may be omitted.

5-6. 150 BAL CONVERSION.

a. To convert the 135 BAL function to a 150 BAL

Table 5-1. Required Test Equipment

INSTRUMENT TYPE	REQUIRED CHARACTERISTICS	RECOMMENDED MODEL
Oscillator	Frequency Range: 20Hz to 3MHz Levels: -80dBm to +30dBm Accuracy: ± 0.1 5dB	-hp- 654A
Oscillator	Frequency Range: 100Hz to 20kHz Amplitude: 30V	-hp- 201 C
Transformer	Line matching	-hp- 11004A
Voltmeter, digital	Function: AC and DC Accuracy: $\pm 1\%$	-hp- 3440A/3445A
Amplifier	Voltage gain: 20 dB	-hp- 467A
Output:	+/-20V peak at 0.5A peak	
Voltmeter, AC	Frequency Range: 20Hz-4MHz Accuracy: $\pm 2\%$	-hp- 400FL
Termination	50 ohms $\pm 25\%$	-hp- 11048B
Termination	75 ohms $\pm 25\%$	-hp- 11094A
Cables	Balanced BNC to 310 plug	See Figure 5-1.
Adapter	BNC to 358 plug	Trompeter Electronics No. AD-1W
Resistors	576 ohms $\pm 1\%$ (1) 875 ohms $\pm 1\%$ (1) 300 ohms 0.1 % (4) 600 ohms $\pm 0.1\%$ (4) 135 ohms $\pm 0.1\%$ (4) 75 ohms $\pm 0.1\%$ (4) 900 ohms $\pm 0.1\%$ 150 ohms $\pm 1\%$ (2) 100 kilohms 1% (1)	-hp- Part No. 06984598 (Use 825 ohm, 0757-0731 and 49.9 ohm, 0698A4110 in series) -hp- Part No. 0698-6295 -hp- Part No. 0698-7408 -hp- Part No. 0698-7364 -hp- Part No. 0698-7363 Use 600 and 300 in series (0.1%) -hp- Part No. 0698-6774 -hp- Part No. 0757-0465

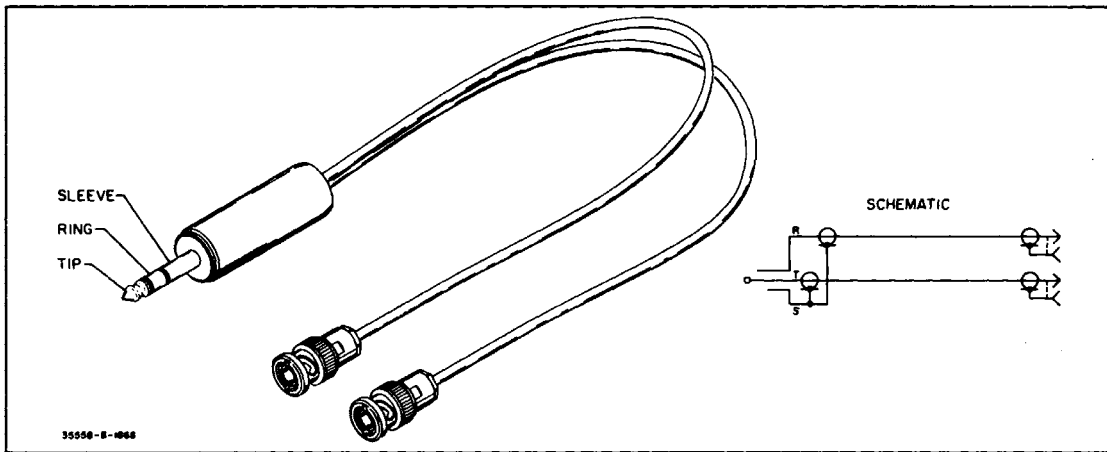

Figure 5-1. Balanced BNC to 310 Plug

function, remove or clip the shorting bar from across A1 R17 (see Figure 7-2).

- b. Remove the 150 BAL decal from the small envelope supplied with the set and stick it over the existing 135 BAL decal.
- c. Adjust the 150 function as described in Paragraph 5-20 in this manual.

5-7. PERFORMANCE CHECKS.

5-8. The performance checks presented in this section are in-cabinet checks designed to compare the Model 3555B with its published specifications. These checks can be used for incoming inspection, periodic maintenance checks and to verify performance after adjustment or repair. A performance check test card appears at the end of this section which can be used to record the specification performance of your set.

5-9. LEVEL ACCURACY CHECKS.

- a. Connect only the 654A and 3555B as shown in Figure 5-2 and set the 3555B controls as follows:

FUNCTION..... CARRIER, 75 UNBAL
 INPUT TMS, TERM
 RANGE..... +10dBm

- b. Set the 654A frequency to 20kHz, IMPEDANCE to 75 UNBAL and adjust the output level for +10dBm. If the calibration of the 654A is questionable, first connect the output of the 654A through a 75 ohm termination, directly to the input of the 3440A/3445A (3555B not connected) and measure the voltage. This level should be 866mV rms. If it is not, adjust the 654A amplitude control until it is and note the 654A meter indication for future reference. Now that the 654A calibration has been verified, disconnect

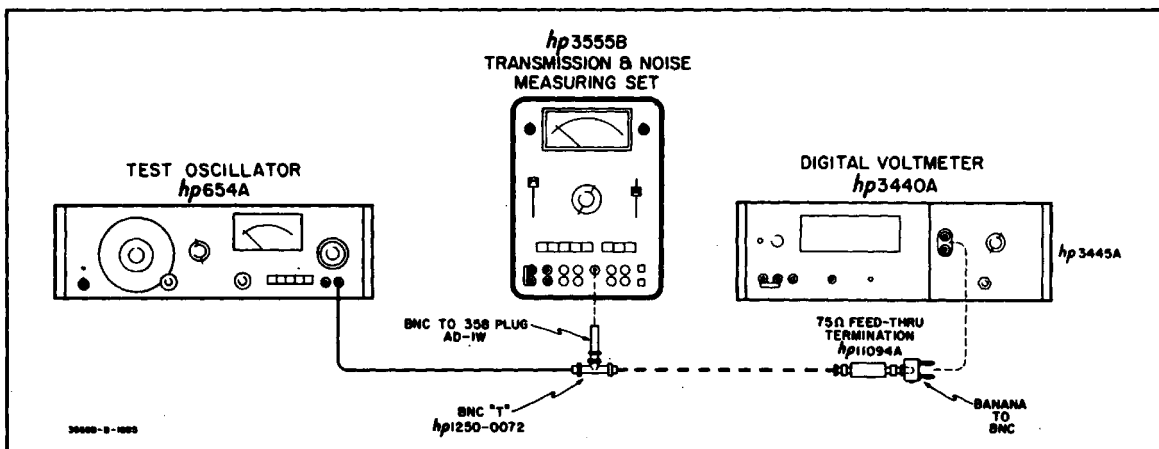

Figure 5-2. Level Accuracy Check

Table 5-2. 75 UNBAL Carrier Accuracy Check

RANGE	3555B INDICATION (dBm)		
	30Hz to 1MHz	FREQUENCY 100Hz to 600kHz	1MHz to 3MHz
+10dBm	+10 ±0.5	+10 ±0.2	+10 ±0.5 ±10% of meter indication in dBm
0dBm	0 ±0.5	0 ±0.2	0 ±0.5 ±10% of meter indication in dBm
-10dBm	-10 ±0.5	-10 ±0.2	-10 ±0.5 ± 0% of meter indication in dBm
-20dBm	-20 ±0.5	-20 ±0.2	-20 ±0.5 ±10% of meter indication in dBm
-30dBm	-30 ±0.5	-30 ±0.2	-30 ±0.5 ±10% of meter indication in dBm
-40dBm	-40 ±0.5	-40 ±0.2	40 ±0.5 ±10% of meter indication in dBm
-50dBm	-50 ±0.5	-50 ±0.2	-50 ±0.5 ±10% of meter indication in dBm

the 3440A/3445A and reconnect the output of the 654A to the input of the 3555B. Maintain the 654A meter reference throughout the remainder of the following checks.

- c. The 3555B meter should indicate 0dBm ±0.1 dBm.
- d. Check all the RANGES and frequencies listed in Table 5-2 for the specified tolerances. Be sure to maintain the 654A reference established in step b.
- e. Change the 654A to 600 BAL and change the 3555B to CARRIER, 600 BAL. Connect the 654A 600 BAL output to the 3555B input using a balanced cable.
- f. Check the RANGES and frequencies in Table 5-3, using the same procedure described for the 75 UNBAL function.
- g. Change the 654A to 135 BAL and change the 3555B to 135 BAL. Repeat step e for the same RANGES and tolerances indicated for the CARRIER 600 BAL function in Table 5-3.
- h. Change the 3555B to VF/Nm, 600 BAL and change the 654A to 600 BAL. Check the +10dBm thru -80dBm ranges in Table 5-4 for the tolerances indicated.
- i. Change the 3555B to 900 BAL and connect a 150 ohm ± 1% resistor in series with each input lead. Readjust the 654A for 0dBm. Repeat the checks in Table 5-4 for the same tolerances.
- j. To check the top two ranges, connect the equipment as shown in Figure 5-3 and set the 3555B controls as follows:
 FUNCTION..... VF/Nm 600 BAL
 INPUT TMS, TERM
 RANGE.....+20dBm
- k. Adjust the 201C for 7.75V on the 3440A/3445A at 100Hz.

- l. Tune the 201 C from 100Hz to 20kHz, maintaining 7.75V on the 3440A/3445A. Between 100Hz and 15kHz, the 3555B indication must not change more than ±0.2dBm. Between 15 kHz and 20kHz, the indication must not change more than ±0.5dBm.
- m. Check the +30dBm range using the procedure described in Steps j through l, except change the 3555B range to +30dBm and change the 201C output level for 24.49V.
- n. To check the 900 ohm function on the +20dBm and +30dBm ranges, connect a 300 ohm +0.1% resistor in series with the 3555B input in Figure 5-3.
- o. Change the 3555B to 900 BAL and change the range to +20dBm.
- p. Adjust the 201 C output for 9.49V as indicated on the 3440A/3445A.
- q. Check for the tolerances indicated in Table 5-4 for the +20dBm range.
- r. Change the 3555B range switch to +30dBm and adjust the 201C for 30V on the 3440A/3445A. Check for the tolerances indicated in Table 5-4 for the +30dBm range.

Table 5-3. Carrier Level Accuracy

RANGE	3555B Indication (dBm)		
	135 600	1kHz - 600kHz 1kHz - 150kHz	10kHz - 300kHz 10kHz - 100kHz
-50 thru +10dBm	±0.5		±0.2*

*Increase specification by ±0.3dB on 135 ohms (or 150 ohms) when not battery powered.

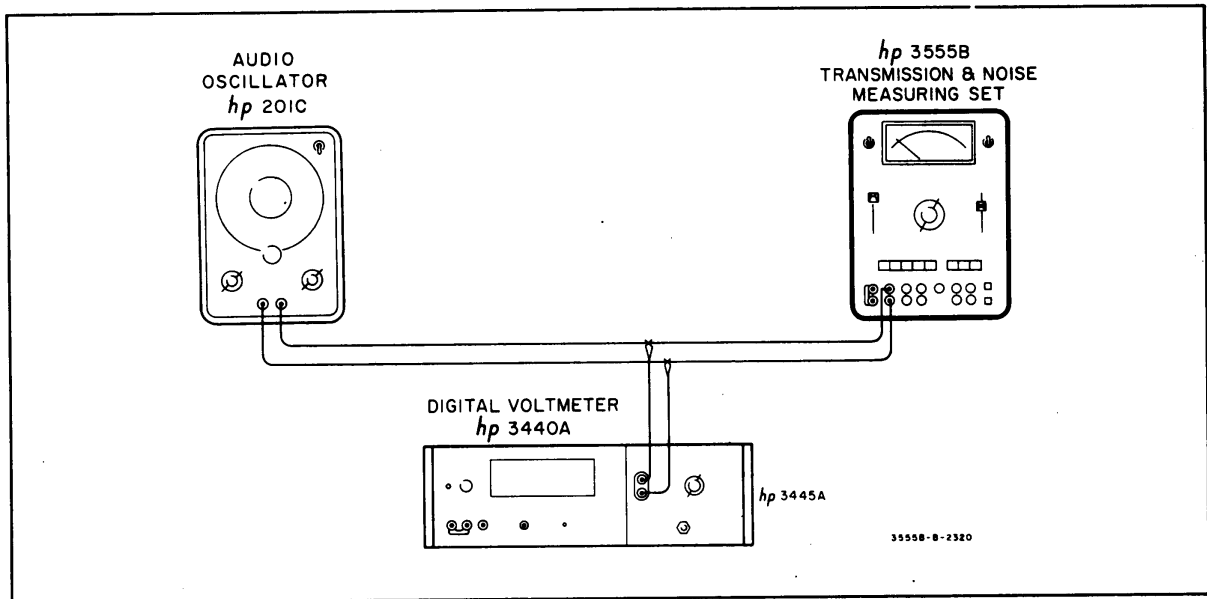

Figure 5-3. +20dBm and +30dBm Level Accuracy Check

5-10. RETURN LOSS CHECK.

- a. To make a return loss check it will first be necessary to construct a balanced bridge utilizing 0.1% resistors for each of the four 3555B impedances. Figure 5-4 shows the equipment test set-up to be used. For this check to be meaningful, all test leads should be kept short. The leads connecting the 3555B to the bridge should be short clip leads and should be kept away from each other and from other leads. Keep all the instruments away from other instruments that may be referenced to earth ground.
- b. Connect the equipment as shown in Figure 5-4 and set the 3555B controls as follows:

FUNCTION.....VF/Nm, 600 BAL
 INPUTTMS, TERM
 RANGE0dBm

NOTE

The 3555B does not have to be turned on for this check. If at any frequency the 3555B return loss check is out of specification, check the reference at that frequency as described in the following procedure.

- c. Set the 654A frequency to 1kHz. Temporarily close S1 in Figure 5-4 and adjust the 654A output level for an up scale indication on the 400FL AC Voltmeter.

Table 5-4. VF/Nm Level Accuracy Checks 600 BAL and 900 BAL
 -80dBm through +30dBm

RANGE	20Hz to 20kHz	40Hz to 15kHz	100Hz to 20kHz	100Hz to 15kHz
+30dBm			+30 ±0.5	+30 ±0.2
+20dBm			+20 ±0.5	+20 ±0.2
+10dBm			+10 ±0.5	+10 ±0.2
0dBm	0 ±0.5	0 ±0.2		
-10dBm	-10 ±0.5	-10 ±0.2		
-20dBm	-20 ±0.5	-20 ±0.2		
-30dBm	-30 ±0.5	-30 ±0.2		
-40dBm	-40 ±0.5	40 ±0.2		
-50dBm	-50 ±0.5	-50 ±0.2		
-60dBm	-60 ±0.5	-60 ±0.2		
-70dBm	-70 ±0.5			
-80dBm	-80 ±0.5			

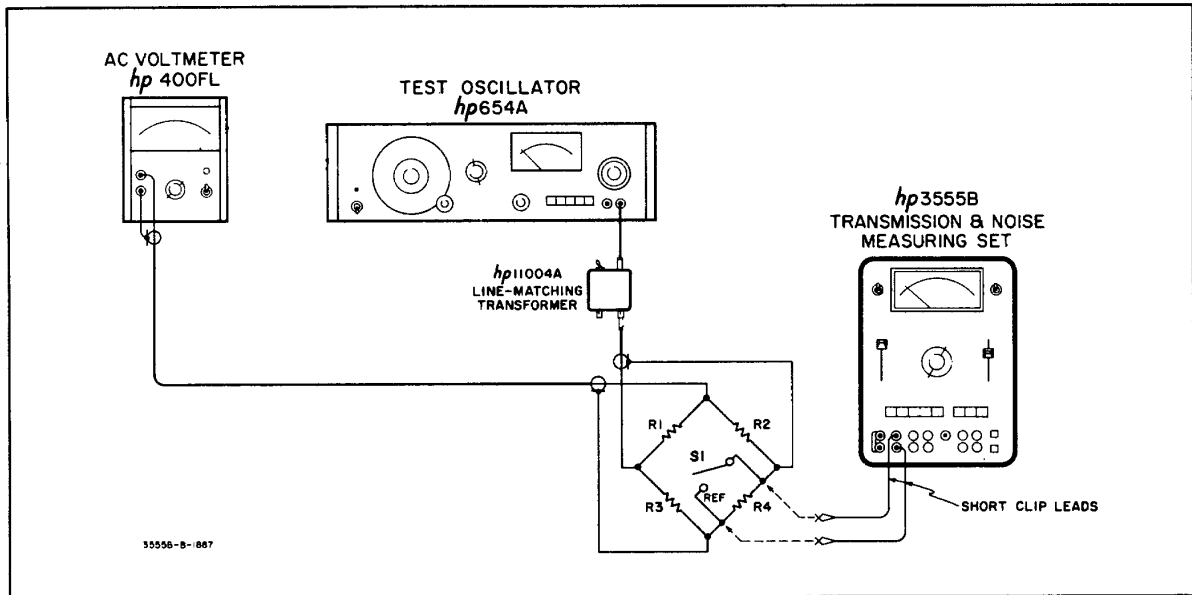

Figure 5-4. Return Loss Test Set-Up

- d. Open S1 and down range the 400FL for an on-scale indication. This indication subtracted from the reference established in step c, is the bridge balance and should be greater than the return loss specification.
- e. Unplug or disconnect R4 in Figure 5-4 and connect the 3555B tip and ring in its place. Be sure to use short clip leads.
- f. Momentarily close S1 and recheck the reference on the 400FL. Open S1 in Figure 5-4 and down range the 400FL for an on-scale indication. This indication must be down at least 30dB from the reference.
- g. Tune the 654A from 50Hz to 20kHz. The 400FL indication must remain at least 30dB down from the reference.
- h. Change the 3555B FUNCTION to CARRIER 600 BAL and repeat steps f and g between 3kHz and 150kHz. Return loss must be at least 26dB down from the reference.
- i. Change the bridge resistors in Figure 5-4 to 900 ohms f 0.1% (use 300 ohms + 0.1% in series with 600 ohms $\pm 0.1\%$) and change the 3555B FUNCTION to VF/Nm 900 BAL. Be sure to reset the reference level after the resistors are changed. Check the return loss between 50 Hz and 20 kHz. The return loss must be better than 30 dB.

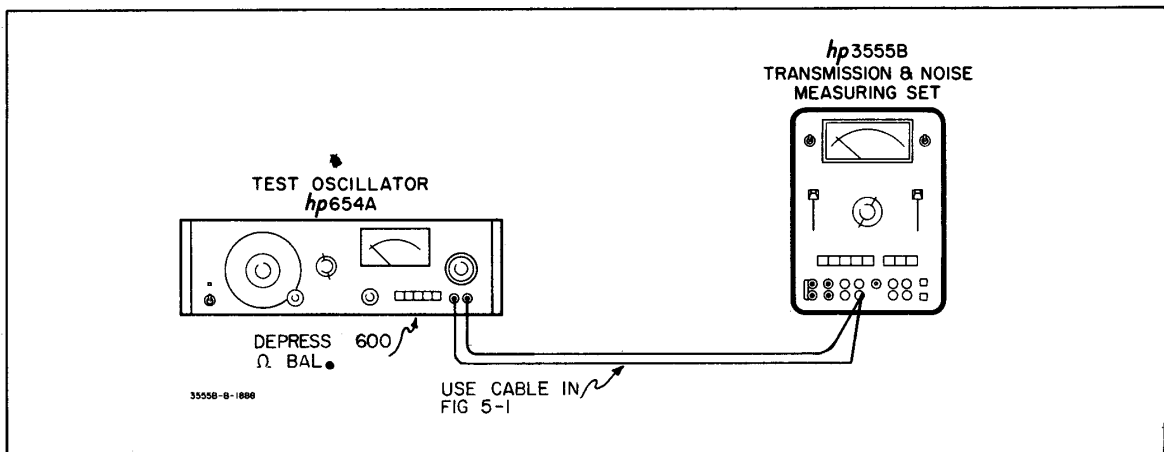

FIG 5-1

Figure 5-5. Filter Response Test Set-UP

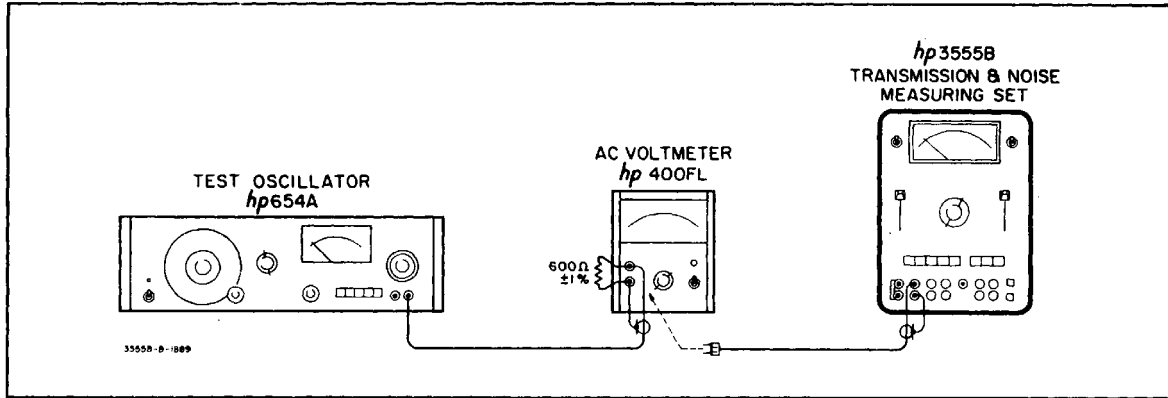

Figure 5-6. Bridging Loss Test Set-Up

- j. Change the bridge resistors in Figure 5-4 to 135 ohms +0.1% and change the 3555B FUNCTION to 135 BAL. Check the return loss between 1kHz and 600kHz. The return loss must be better than 26dB down from the reference.
- k. Change the 3555B input connection to the 75 UNBAL jack. Change the resistors in Figure 5-4 to 75 ohms +0.1% and change the 3555B FUNCTION to CARRIER 75 UNBAL.
- l. Check the return loss between 1kHz and 3MHz. The return loss must be better than 30dB down from the reference.

- 1. Connect the equipment as shown in Figure 5-5 with S1 in position 1 and set the 3555B controls as follows:

FUNCTION..... VF/Nm 600
 INPUT NOISE BRDG
 RANGE 0dBm

- 2. Adjust the output of the 654A for 0dBm at a frequency of 1 kHz.
- 3. Check the frequencies listed in Table 5-5 for the tolerances indicated.

- b. 3kHz FLAT FILTER RESPONSE
 - 1. Set the 654A frequency to 1kHz and adjust the output level for 0dBm.
 - 2. Check the frequencies listed in Table 5-5 for the tolerances indicated.
- c. 15kHz FLAT FILTER RESPONSE

5-11. FILTER RESPONSE CHECKS.

- a. C MSG FILTER RESPONSE

Table 5-5. Filter Response Checks

FREQUENCY	C MSG (dBm)	3kHz FLAT (dBm)	15kHz FLAT (dBm)	PROGRAM (dBm)
60Hz	-55.7 ±2	0 ±1.75	0 ±1.75	-17.3 ±2
200Hz	-25 ±2			
250Hz		0 ±1	0 ±1	-6.6 ±1
500Hz	-7.5 ±1			
1kHz	0(Ref)	0(Ref)	0(Ref)	0(Ref)
2kHz	-1.3 ±1	-0.5 ±1.75		4.8 ±2
2.5kHz	-1.4 ±1	-1.5 ±2		+6.5 ±2
3kHz		-3 ±3		
4kHz	-14.5 ±3			+6.5 ±2
5kHz	-28.5 ±3		0 ±1	+6.5 ±2
6kHz				+6.4 ±3
8kHz				+4 ±3
10kHz			-0.5 ±1.75	-8.5 ±4
12.5kHz			-1.5 ±2	
15kHz			-3 ±3	

1. Reset the 654A output level for 0dBm indication on the 3555B meter at a frequency of 1kHz.
 2. Check the frequencies listed in Table 5-5 for the tolerances indicated.
- d. **PROG FILTER RESPONSE**
1. Reset the 654A frequency to 1kHz and adjust the output level for 0dBm indication on the 3555B meter.
 2. Check the frequencies listed in Table 5-5 for the tolerances indicated.

5-12. BRIDGING LOSS.

- a. Connect the equipment as shown in Figure 5-6 and set the 3555B controls as follows:
 FUNCTIONVF/Nm 600
 INPUT.....TMS BRDG
 RANGE..... 0dBm
- b. Adjust the output of the 654A (600 ohm function) for 0dBm indication on the 400FL at a frequency of 1kHz.
- c. Connect the 3555B to the 400FL input. The indication on the 400FL should not drop more than 0.3dB.
- d. Change the FUNCTION switch to CARRIER 600 and repeat the above procedure at a frequency of 10kHz. The 400FL indication should not drop by more than 0.05dB.
- e. Change the equipment setup by connecting a 300 ohm $\pm 1\%$ resistor in series with the 400FL input and change the resistor connected across the 400FL input to 900 ohms $\pm 1\%$.

- f. With the 400FL set to the 0dB range, adjust the 654A output level for exactly 0dB indication on the 400FL.
- g. Change the 3555B FUNCTION to VF/Nm 900 and connect the 3555B input to the 400FL input terminals. The 400FL indication must not drop by more than 0.3dB.

5-13. INPUT BALANCE.

- a. Set the 3555B controls as follows:
 FUNCTIONVF/Nm 600
 INPUT.....TMS BRDG
 RANGE..... 0dBm
- b. Connect the 654A 600 ohm output to-the tip and ring input of the 3555B. Set the output frequency of the 654A to 60Hz and adjust the amplitude control for 0dBm indication on the 3555B meter.
- c. Change the equipment setup to that shown in Figure 5-7.
- d. Change the 3555B RANGE switch to -80dBm. The 3555B indication (meter + RANGE setting) must be down at least 80dB.
- e. Change the 3555B RANGE switch to -70dBm and tune the 654A to 6kHz. The 3555B indication must be down at least 70dB.
- f. Change 3555B RANGE to -60dBm and tune the 654A to 20kHz. The 3555B indication must be down at least 50dB.
- g. Change the 3555B FUNCTION switch to

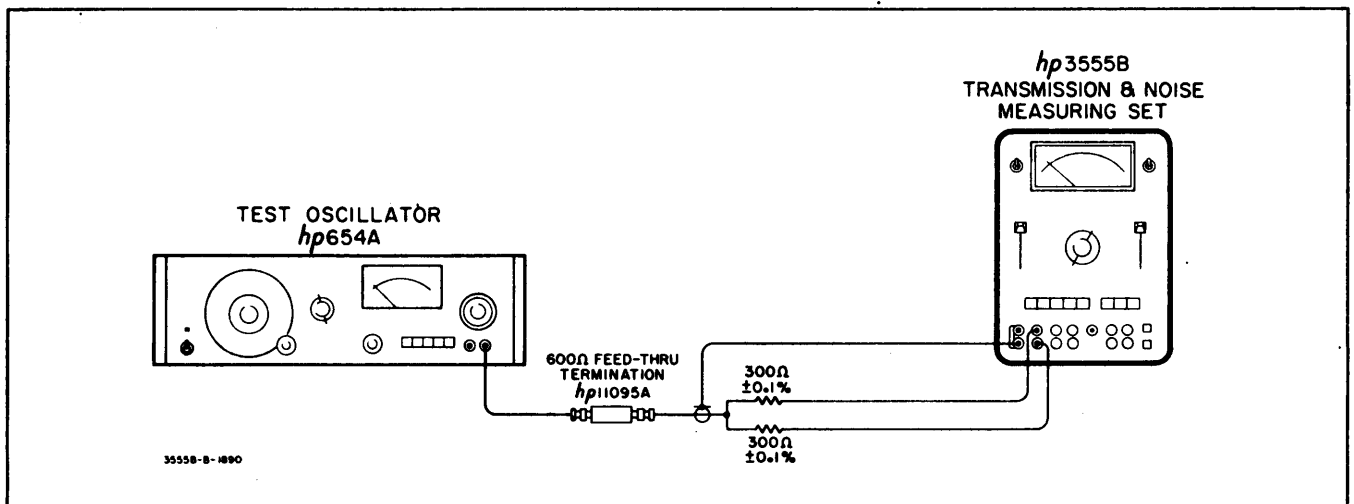

Figure 5-7. Input Balance Test Set-Up

CARRIER 600 and repeat the above procedure. Between 1kHz and 10kHz, the balance must be greater than 70dB. Between 10kHz and 100kHz, the balance must be better than 60dB. Between 100kHz and 600kHz, balance must be better than 40dB.

5-14. ADJUSTMENT AND CALIBRATION PROCEDURE.

5-15. The following is a complete adjustment and calibration procedure for the Model 3555B. These adjustments should be performed only after it has been determined by the performance checks that the set is not operating within its published specifications.

5-16. POWER SUPPLY CHECK.

5-17. Before attempting the following calibration procedures, first check the power supply voltage to be sure that it is correct and that the ripple voltage is not abnormal. To do this perform the following steps.

NOTE

Calibration of the 3555B should be performed with the set operating from the internal battery except for the power supply ripple check in the following steps. Operate the set from the ac power source long enough to make this check and then return the set to internal battery operation. This is accomplished by changing the position of the slide switch mounted on the side of the set. When operating from the battery, disconnect the ac power cord from the set.

- a. Remove the set from the case and connect the 3440A/3445A dc voltmeter between the -20V supply and ground. The negative side of A3C34 is a convenient place.
- b. Turn the set on. The 3440A/3445A should indicate -20 volts $\pm 1.0V$.
- c. Connect the 400FL AC Voltmeter to the negative side of A3C34 and measure the ripple voltage. The maximum allowable ripple is 200uV rms.

5-18. 75 UNBAL CALIBRATION.

- a. Connect the 654A and 3440A/3445A as shown in Figure 5-2 and set the 3555B controls as follows:
 FUNCTION 75 UNBAL
 INPUT TMS, TERM
 RANGE +10dBm
- b. Set the 654A frequency to 10 kHz, 75 UNBAL, and adjust the output level for 866 mV (+ 10 dBm) indication on the 3440A/3445A.

- c. Set the 654A meter for a reference indication and be sure to maintain this indication throughout the following procedures unless otherwise instructed. Disconnect the 3440A/3445A voltmeter.
- d. Change the 654A to -50dBm and change the 3555B RANGE switch to -50dBm.
- e. Disconnect the 3440A/3445A, the 11094A termination and the cable. Connect the 654A output directly to the 3555B input.
- f. Adjust A3R43 for 0dBm indication on the 3555B meter.
- g. Change 654A frequency to 3MHz maintaining the reference established on the 654A meter.
- h. Adjust A3C8 for 0dBm indication on the 3555B meter.

5-19. ATTENUATOR CALIBRATION.

- a. Remove the FUNCTION board and replace it with the test board supplied with the set.
- b. With the equipment and controls set as in the preceding check, change the 3555B RANGE to 40dBm and change the 654A attenuator to -40dBm. Change the 654A frequency to 100kHz.
- c. Adjust A2C12 for 0dBm indication on the 3555B meter.
- d. Change the 3555B RANGE switch to -30dBm and change the 654A attenuator to -30dBm. Adjust A2C7 for 0dBm indication on the 3555B meter.
- e. Change the 3555B RANGE switch to -20dBm and change the 654A attenuator to -20dBm. Adjust A2C4 for 0dBm indication on the 3555B meter.
- f. Change the 3555B RANGE switch to +10dBm and change the 654A attenuator to +10dBm. Adjust A2C1 for 0dBm indication on the 3555B meter.
- g. Check the frequencies listed in Table 5-2 for the tolerance indicated. If any of the checks in Table 5-2 do not meet the indicated tolerances, repeat steps b through f.

5-20. FUNCTION CALIBRATION.

- a. Remove the test board from the set and install the function board assembly. Connect the 654A balanced output to the 3555B balanced input terminals. See Figure 5-5. Set the 3555B controls as follows:
 FUNCTION..... CARRIER, 600 BAL
 INPUT TMS, TERM
 RANGE -50dBm
- b. Set the 654A frequency to 10kHz and adjust the output attenuators for -50dBm output level, using the 600 BAL output function.

- c. Adjust A3R15 for 0dBm indication on the 3555B meter.
- d. Change the 654A frequency to 1kHz. Change the 3555B FUNCTION switch to VF/Nm, 600 BAL. Compare the 3555B meter indication with the indication in step c. If any difference exists, adjust A3R15 to split the difference between these two indications.

NOTE

If the set is being operated from the ac line ground currents may be encountered on the low ranges, particularly if other instruments are connected in any way to the 3555B. In order to eliminate this problem, operate the set from its own internal battery or use the C MSG filter. If the C MSG filter is used, perform the filter calibration described in Paragraph 5-24 and then perform the following step.

- e. Change the 654A to -80dBm output level at 1.00kHz. Change the 3555B RANGE switch to -80dBm. Adjust A3R26 for 0dBm indication on the 3555B meter.
- f. Change the 654A to 135 BAL (150 BAL) and change the 3555B FUNCTION to 135 BAL (150 BAL). Adjust A3R24 for 0dBm indication on the 3555B meter.
- g. Change the 3555B RANGE switch to -50dBm, INPUT switch to TMS TERM, and the FUNCTION switch to VF/Nm 600 BAL. Change the 654A to 1kHz at an output level of -50dBm, 600 BAL. Adjust the AMPLITUDE control for exactly 0dBm indication on the 3555B meter.
- h. Change the 3555B FUNCTION switch to 900 BAL without changing anything else. Adjust A3R20 for -0.15dBm indication on the 3555B meter.

5-21. FREQUENCY RESPONSE ADJUSTMENT.

- a. The following adjustment consists of selecting fixed values for frequency compensation at 20Hz, 600 BAL, -70dBm and 20kHz, 600 BAL, -70dBm.
- b. Connect the 654A 600 BAL output to the 3555B input. Set the 3555B controls as follows:

FUNCTION VF/Nm 900 BAL
 INPUT TMS, TERM
 RANGE 0dBm

RESPONSE DAMP

- c. Set the 654A (600 BAL) output level to 0dBm at a frequency of 20Hz. The 3555B meter should Section V indicate -0.1SdBm +0.3dBm. Note this indication.
- d. Change the 654A output level to -70dBm at a frequency of 20Hz. Change the 3555B RANGE switch to -70dBm and change the FUNCTION to VF/Nm 600 BAL. The 3555B meter should indicate 0dBm +0.3dBm. Note the exact indication.
- e. Compensation should be made between the 900 BAL, 0dBm check (step c) and the 600 BAL, -70dBm check (step d). To raise the level, increase the value of A3R72 until the 900 BAL 0dBm check indicates high by the same amount that the 600 BAL, -70dBm check indicates low. The total difference should not exceed +0.3dBm.

5-22. COMMON MODE ADJUSTMENT.

- a. Connect the equipment as shown in Figure 5-5 and set the 3555B controls as follows:
 FUNCTION VF/Nm, 600 BAL
 INPUT TMS, TERM
 RANGE 0dBm
- b. Set the 654A frequency to 20kHz and adjust the output level of the 654A for 0dBm indication on the 3555B meter.
- c. Disconnect the left output terminal on the 654A and short the tip and ring together on the cable. Down range the 3555B RANGE switch for an on-scale indication.
- d. Adjust A1C7 for minimum indication on the 3555B meter. This indication must be down at least 60 dB.
- e. Change the 3555B FUNCTION switch to CARRIER, 600 BAL and change the 654A frequency to 100kHz.
- f. Use the procedure described above and adjust A1C4 for minimum indication on the 3555B meter. This indication must be down at least 40dB.

5-23. BALANCE CHECK.

- a. First check the balance as described in paragraph 5-13 to be sure that the balance does not meet specifications. If it does, disregard this step. If it does not perform the following procedure.
- b. Since there are no adjustments for balance it will be necessary to change the value of a fixed factory selected capacitor. To adjust the balance on the

CARRIER function, change C4. To change the balance on VF/Nm, change the value of A1C9.

- c. To determine whether the value of these capacitors should be increased or decreased, lightly touch the tip and ring banana jack insulators and watch the direction in which the meter indication goes. The side (tip or ring) that causes the meter indication to decrease needs added capacitance. The capacitance should be changed in very small steps and checked again.

5-24. FILTER CALIBRATION.

- a. Connect the equipment as shown in Figure 5-5 with S1 in position 1 and set the 3555B controls as follows:

FUNCTIONVF/Nm, 600 BAL
 RANGE0dBm
 INPUT NOISE, TERM
 NOISE WTG3kHz FLAT

- b. Connect a frequency counter to the 3555B AC MON terminals and adjust the 654A frequency to exactly 1.00kHz as indicated on the frequency counter. Adjust the 654A output level for exactly 0dBm.
- c. Adjust A4R3C for 0dBm indication on the 3555B meter.
- d. Change the NOISE WTG switch to 15kHz FLAT and note the meter indication. If it differs from the indication set up in step c, adjust A4R3C to split the difference between these two indications.
- e. Change the 3555B NOISE WTG switch to C MSG and adjust A4R3A for 0dBm indication on the 3555B meter.
- f. Change the 654A frequency to 3.00kHz and adjust A4R3D for an indication of -2.15dBm on the 3555B meter.
- g. Repeat steps e and f until both points are within specifications.
- h. Change the 3555B NOISE WTG switch to PROG and change the 654A frequency back to 1.001Hz with the output level still set to 0dBm. Adjust A4R3B for 0dBm indication on the 3555B meter.

5-25. ASSEMBLY REMOVAL.

5-26. To gain access to the various assemblies in the 3555B use the following procedure.

- a. Turn the set off and remove it from the case by removing four front panel screws.
- b. Unplug the small cable on the A3 assembly.

- c. Remove the two screws that secure the A3 board.
- d. Gently lift up the bottom of the A3 board to unplug it from the A1 FUNCTION assembly.
- e. Hold the bottom of the A3 board high enough to clear the FUNCTION board and pull the A3 assembly out. This is easily accomplished by gently rocking the board back and forth while pulling it down (toward the FUNCTION board).
- f. Once the A3 assembly has been removed, the A1 FUNCTION board can be removed by pulling it out.
- g. To gain access to the RANGE attenuator (A2), Input switch and the NOISE WTG switch, the shield must be removed. To do this, remove the two screws on each side of the set and lift out the shield.
- h. To reassembly the set, use the reverse of the procedure described above.

5-27. TROUBLESHOOTING PROCEDURES.

5-28. The following information is supplied to assist in locating a malfunction in the set in a minimum of time. It should first be determined that a malfunction does indeed exist and that the trouble is not external to the set.

5-29. Before starting to troubleshoot the set, use the front panel controls to determine exactly which function, if any, is operating properly. Table 5-6 can aid you in this analysis. In many cases a good front panel analysis of the symptoms can lead you directly to the trouble.

5-30. To simplify troubleshooting the following information is supplied:

- a. Troubleshooting Tree - - The troubleshooting tree (Figure 5-8) is based on the half-split method of troubleshooting a set. The trouble can be isolated to a general area or block using this tree. Once the trouble has been isolated to an area, a reference is given to a paragraph where more specific information can be found.
- b. Functional Block Diagram - - The functional block diagram can also be used to isolate the trouble to block. The diagram contains all of the essential blocks that make up the set and includes voltage levels, test points and adjustments. The troubleshooting tree and functional block diagram are keyed together by the numbers with a circle around them. If the levels or indications in your set do not agree with those on the functional block diagram or troubleshooting tree, refer to the paragraph indicated for more detailed information.

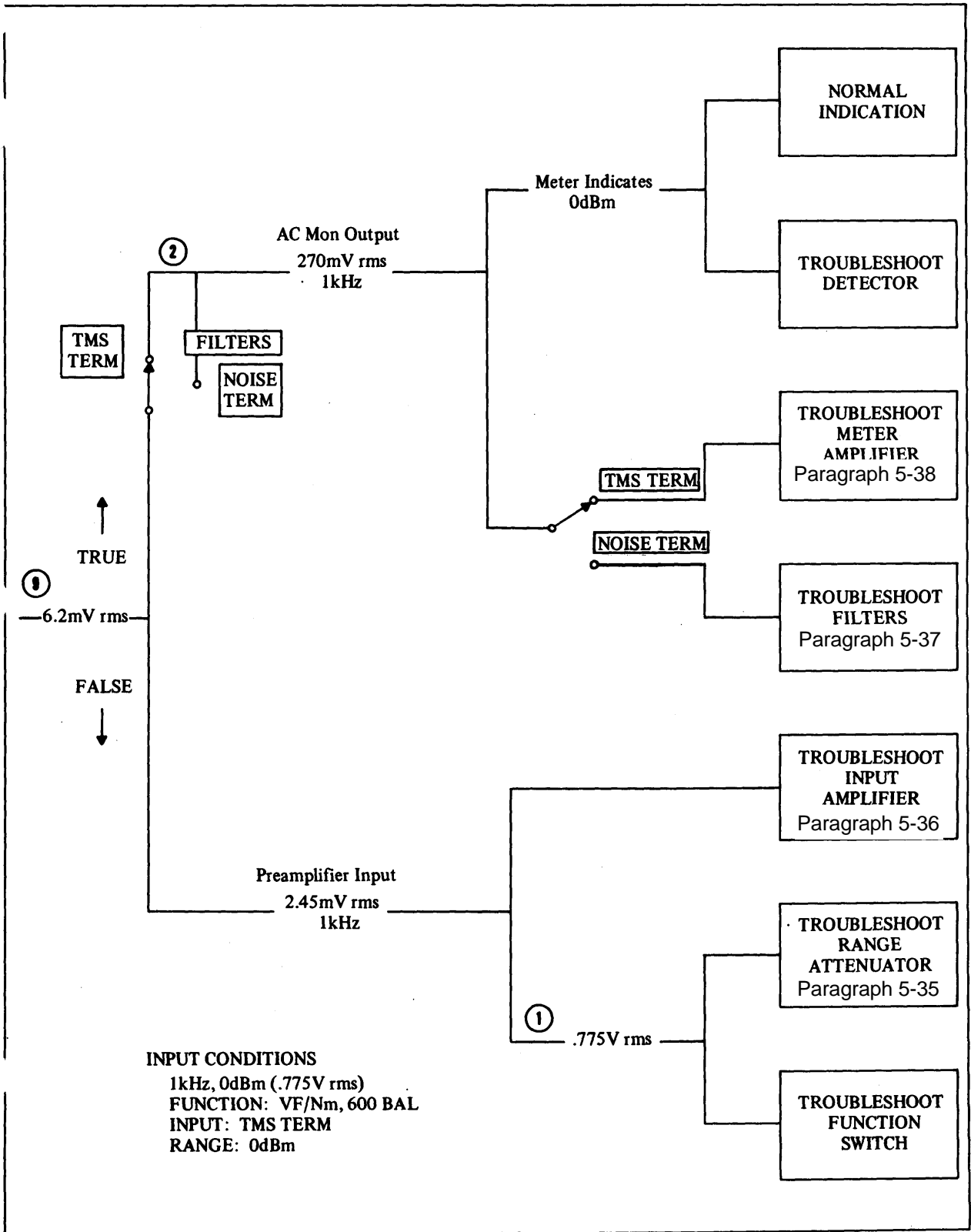

Figure 5-8. Troubleshooting Tree

Table 5-6. Front Panel Trouble Analysis

INPUT CONDITIONS	FUNCTION	3555B SHOULD INDICATE (RANGE + METER)*	SET ACTUALLY INDICATES	CORRECTIVE ACTION
FUNCTION: VF/Nm 1kHz, 0dBm, 600 BAL	DIAL BAT Input: TMS, TERM VF/Nm: 600 BAL	In green area, BAT GOOD 0dBm \pm 0.2dBm		Replace battery Refer to Paragraph 5-34
	Change INPUT to BRDG RANGE to +10dBm	+6dBm \pm 0.2dBm		Refer to Paragraph 5-34
	Depress 900 BAL	+4.2dBm \pm 0.2dBm		Refer to Paragraph 5-34
	INPUT to TERM RANGE to 0dBm	-0.1 5dBm \pm 0.2dBm		Refer to Paragraph 5-34
FILTERS	INPUT: NOISE TERM NOISE WTG: 3kHz FLAT VF/Nm, 600 BAL	0dBm 0dBm \pm 0.2dBm		Refer to Paragraph 5-37 Refer to Paragraph 5-37
	Change to C MSG	0dBm \pm 0.2dBm		Refer to Paragraph 5-37
	Change to 15kHz FLAT	0dBm \pm 0.2dBm		Refer to Paragraph 5-37
	Change to PROG	0dBm \pm 1dBm		Refer to Paragraph 5-37
	FUNCTION: CARRIER 20kHz, 0dBm 600 BAL	INPUT: TMS, TERM FUNCTION: CARRIER 600 BAL	0dBm	
Change INPUT to BRDG RANGE to +10dBm		+6dBm \pm 0.5dBm		Refer to Paragraph 5-34
Depress 135 BAL RANGE to +20dBm		+12.6dBm \pm 0.5dBm		Refer to Paragraph 5-34
Change INPUT to TERM RANGE to 0dBm		-2.2dBm \pm 0.5dBm		Refer to Paragraph 5-34
Change to 75	UNBAL INPUT: TMS, TERM FUNCTION: 75 UNBAL RANGE: 0dBm	0dBm \pm 0.2dBm		Refer to Paragraph 5-34
	Change INPUT to BRDG RANGE to 10dBm	\pm 6dBm +0.2dBm		Refer to Table 5-8
	Change INPUT back to TERM RANGE to 0dBm	0dBm \pm 0.2dBm		Refer to Table 5-8
RANGE 1kHz, 600 BAL, LEVEL +10dBm LEVEL -10dBm LEVEL -20dBm	Change RANGE to +10dBm FUNCTION: VF/Nm 600 BAL	+10dBm \pm 0.2dBm		See Paragraph 5-35
	Change RANGE to -10dBm	-10dBm \pm 0.2dBm		See Paragraph 5-35
	Change RANGE to -20dBm	-20dBm \pm 0.2dBm		See Paragraph 5-35

Table 5-6. Front Panel Trouble Analysis (Cont'd)

INPUT CONDITIONS	FUNCTION	3555B SHOULD INDICATE (RANGE + METER)*	SET ACTUALLY INDICATES	CORRECTIVE ACTION
LEVEL -30dBm	Change RANGE to -30dBm	-30dBm ±0.2dBm		See Paragraph 5-35
LEVEL 40dBm	Change RANGE to 40dBm	-40dBm ±0.2dBm		See Paragraph 5-35, Table 5-9
LEVEL -50dBm	Change RANGE to -50dBm	-50dBm ±0.2dBm		See Paragraph 5-35, Table 5-9
LEVEL -60dBm	Change RANGE to -60dBm	-60dBm ±0.2dBm		See Paragraph 5-35, Table 5-9
LEVEL -70dBm	Change RANGE to -70dBm	-70dBm ±0.2dBm		See Paragraph 5-35, Table 5-9
LEVEL -80dBm	Change RANGE to -80dBm	-80dBm ±0.2dBm		See Paragraph 5-35, Table 5-9
LEVEL 0dBm	RANGE to 0dBm INPUT: TMS, TERM	0dBm Measure 270mV ac ±0.2dBm at AC MON jacks		See Paragraph 5-38
NG CHECK 75 UNBAL, Connect UNBAL signal between tip and ring	RANGE: 0dBm FUNCTION: VF/Nm 600 BAL	Adjust oscillator level for 0dBm on 3555B meter		
Change input connection. Connect signal between tip and ring and sleeve (tip and ring shorted together), ground lead to sleeve	Depress NG button Change RANGE to 40dBm	-40dBm *Some meter jitter may be experienced, but the reading should be within the tolerance indicated.		Refer to Table 5-8

c. Schematics-- The schematic diagrams contain dc voltage levels and signal levels for a specified input condition. This will assist in troubleshooting individual circuits.

5-31. FRONT PANEL TROUBLESHOOTING.

5-32. Before attempting to troubleshoot the set, first determine from the front panel controls exactly which functions are performing properly and which ones are not. In this way, many troubles can be isolated to a specific area and sometimes to a component.

5-33. Table 5-6 is a step by step procedure for checking out the front panel controls. This table indicates what the results should be for each check along with the specified tolerance. A space is provided to enter your results. If these spaces are completed for each check, they will be of great assistance in making further troubleshooting checks. Whenever a discrepancy exists between your results and those

indicated in column 3, refer to the "corrective action" column.

NOTE

This table is designed to help locate catastrophic failures. If your set is only out of the specified tolerances, a complete adjustment and calibration procedure should be performed as described in Paragraph 5-14.

5-34. FUNCTION TROUBLESHOOTING.

a. First determine from the Front Panel Analysis chart (Table 5-6) exactly which function is defective. Refer to Table 5-7 for the probable cause of the malfunction in the FUNCTION switch assembly.

5-35. RANGE TROUBLESHOOTING.

Table 5-7. Function Troubleshooting

DEFECTIVE FUNCTION	VF/Nm	CARRIER
75 UNBAL		A3K2
135 BAL		A1T2, A3K3, A3R22, A3R23, A3L1, A3R24
600 BAL		A1T2
600 BAL	A1T1	
900 BAL	A1T1, A3K1, A3R19, A3R20	
NG	A1R5 thru A1R8, A1C1, A1S3	
HOLD	L1A/B, A1S1 S1	
DIAL BAT	A1S2, A3R59	

- a. First determine from the Front Panel Trouble Analysis chart (Table 5-9) exactly which range or ranges are defective.
- b. Refer to Table 5-9 to determine the changes that take place when switching ranges. Select the attenuator pads and/or gain switching resistors that match your symptom and check them.

5-36. TROUBLESHOOTING THE INPUT AMPLIFIER.

- a. Check the dc voltages as indicated in Figure 7-3 to determine if a catastrophic failure does exist. If the dc voltages are abnormal (greater than + 10% of the indicated level), check for open or shorted components in the area of the abnormal indication.
- b. Check to see that A3K1, A3K2 and A3K3 are operating properly. All relays are de-energized when either of the 600 BAL FUNCTION pushbuttons is depressed. Depress each of the other impedance functions (900 BAL, 135 BAL and 75 UNBAL) to see that A3K1, A3K3 and A3K2 respectively, energize and de-energize properly. If any relay fails to operate

properly, check the relay and the energizing ground supplied through either pins 1, 2 or 3 on XA1.

5-37. FILTER TROUBLESHOOTING.

- a. First determine that the set is operating in the TMS input mode. This bypasses the filters. If the set functions properly in the TMS mode, check each of the filters by applying a 1kHz signal at a 0dBm level to the set. All filters are calibrated for 0dBm indication on the 3555B meter at a frequency of 1kHz.
- b. Since all the amplifiers in Figure 7-1 are used in C MSG, the loss of any one will obviously cause the loss of the C MSG weighting. However, the bad amplifier can be isolated by checking the other filters. Use the following guide to isolate the trouble to a particular amplifier.
 1. First be sure that the filters have the correct operating potential applied. Check the voltage at the junction of A4R49 and A4C33 to be sure that there is -20 volts + 1 volt.
 2. If none of the filters work, check A3 in Figure 7-1 (A4Q 11 through A4Q14).
 3. If the PROG filter does not work but the others do, check A6 (A4Q5 and A4Q6).
 4. If C MSG does not work but the others do, check A1, A4 and A5.
- c. After the trouble has been isolated to an amplifier, check the dc potentials indicated on the schematic diagram. This will normally isolate the trouble to a component. If the dc levels are correct but the filter response is out of tolerance, no attempt should be made to change the filter characteristics. Return the filter to your nearest -hp- Sales and Service office listed in the back of this manual.

5-38. TROUBLESHOOTING THE METER AMPLIFIER AND DETECTOR.

- a. Inject a 1kHz, 0dBm signal (.775V rms) into the 3555B and set the INPUT switch to TMS TERM, RANGE to 0dBm and the FUNCTION to VF/Nm, 600 BAL. Measure the signal at the input of the meter amplifier (XA3 pin 9). The signal level should be 6.2mV rms. If not the malfunction is ahead of the meter amplifier (refer to troubleshooting tree, Figure 5-8).

Table 5-8. FUNCTION Switch Resistance Values

NOTE

The following resistance measurements were made with C1 shorted. Be sure to remove the short after completion of your measurements.

FUNCTION	INPUT JACKS				DIAL/AC MON JACKS	
	Tip to Ring		Tip to Ground		Ring to Ground	
	BRDG	TERM	BRDG	TERM	BRDG	TERM
DIAL BAT						
NG	80.4 kilohms	80.4 kilohms				
NG HOLD	80.4 kilohms	700 ohms				
VF/Nm						
900 BAL		900 ohms				
900 BAL HOLD		400 ohms				
600 BAL		600 ohms				
600 BAL HOLD		350 ohms				
CARRIER						
600 BAL		600 ohms				
600 BAL HOLD		600 ohms				
135 BAL		135 ohms				
135 BAL HOLD		135 ohms				
75 UNBAL, to Ground		BRDG:	100 kilohms, 120 kilohms, 400 kilohms, 75 ohms			-30dBm thru +30dBm ranges 40dBm Range -50dBm thru -80dBm ranges

DIAL JACKS, resistance is infinite Tip to Ring, Tip to Ground and Ring to Ground on all functions.

b. With a 6.2mV rms signal at XA3 pin 9, measure the signal at XA1, pin 6 or at the AC MON jacks. This signal should be 270mV rms \pm 110%. If not, check A3Q6 through A3Q10 and associated components, using the dc levels indicated in Figure 7-5.

c. If a 270mV rms signal appears at the AC MON jacks, check the detector circuit (A3Q11 through A3Q17).

5-39. FACTORY SELECTED VALUES.

5-40. Table 5-11 lists all the factory selected components in the Model 3555B, along with the purpose of each. Nominal values are shown on the schematic diagrams in Section VII and in the parts list, Table 6-1.

Table 5-9. Range Attenuation and Amplifier Gain

RANGES	Attenuator Pads Used (See Figure 7-3)				Amplifier Gain Switching
	1	2	3	4	
+30	X	X	X		
+20	X	X		X	
+10	X	X			
0		X	X		
-10		X		X	
-20		X			
-30			X		
-40				X	
-50					
-60					A2R13, A2R14
-70					A2R13
-80					
Ranges Affected If Defective	+30 +20 +10	-20 thru +30	+30 0 -30	+20 -10 -40	-60 and -70

Table 5-11. Factory Selected Values

Designator	Purpose
C4	Adjust balance at 600kHz, 135 BAL
A1C5 A1C9	Padding capacitor for A1 C4 Adjust balance 20kHz, 600 BAL (VF/Nm)
A1C8	Padding capacitor for A1C7
A1C10 and A1R12 A1R14	Frequency response correction for A1TI 600 BAL, VF/Nm calibration
A3C1	Padding capacitor for A2C12
A3C15	Frequency response, 20Hz, -80dBm, 600 BAL (VF/Nm)
A3R46	Adjust the bias level for A3Q10 (-10V at + side of A3C24)
A3R72	Response, 20Hz, 600 BAL (VF/Nm) -70dBm and 20Hz, 900 BAL, 0dBm. Compromise between these two settings.
A3R74and A3R75	Meter tracking at 1/3 full scale. Resistors should be the same value.

Table 5-10. Resistance Checks

RANGE (dBm)	Pin 1 to 3	Pin 2 to 3	Pin 1 to 2
-50 thru +30	154 kilohms	0	Infinity
-60	13 kilohms	28.64 kilohms	41.6 kilohms
-70	2.33 kilohms	28.64 kilohms	31 kilohms
-80	0	28.64 kilohms	28.64 kilohms

PERFORMANCE CHECK TEST CARD

Hewlett-Packard Model 3555B
 Transmission and Noise Measuring Set
 Serial No. _____

Tests Performed By _____
 Date _____

DESCRIPTION	CHECK
CARRIER 75 UNBAL LEVEL ACCURACY CHECK 30Hz to 1MHz	
+10dBm Range	_____ +10dBm ±0.5dBm
0dBm Range	_____ 0dBm ±0.5dBm
-10dBm Range	_____ -10dBm ±0.5dBm
-20dBm Range	_____ -20dBm ±0.5dBm
-30dBm Range	_____ -30dBm ±0.5dBm
-40dBm Range	_____ -40dBm ±0.5dBm
-50dBm Range	_____ -50dBm ±0.5dBm
100Hz to 600kHz	
+10dBm Range	_____ +10dBm ±0.2dBm
0dBm Range	_____ 0dBm ±0.2dBm
-10dBm Range	_____ -10dBm ±0.2dBm
-20dBm Range	_____ -20dBm ±0.2dBm
-30dBm Range	_____ -30dBm ±0.2dBm
-40dBm Range	_____ -40dBm ±0.2dBm
-50dBm Range	_____ -50dBm ±0.2dBm
1MHz to 3MHz	
+10dBm Range	_____ +10dBm ±0.5dBm ±10% of meter indication
0dBm Range	_____ 0dBm ±0.5dBm ±10% of meter indication
-10dBm Range	_____ -10dBm ±0.5dBm ±10% of meter indication
-20dBm Range	_____ -20dBm ±0.5dBm ±10% of meter indication
-30dBm Range	_____ -30dBm ±0.5dBm ±10% of meter indication
40dBm Range	_____ -40dBm ±0.5dBm ±10% of meter indication
-50dBm Range	_____ -50dBm ±0.5dBm ±10% of meter indication
CARRIER 135 BAL LEVEL ACCURACY CHECK 1kHz to 600kHz	
+10dBm Range	_____ +10dBm ±0.5dBm
0dBm Range	_____ 0dBm ±0.5dBm
-10dBm Range	_____ -10dBm ±0.5dBm
-20dBm Range	_____ -20dBm ±0.5dBm
-30dBm Range	_____ -30dBm ±0.5dBm
-40dBm Range	_____ -40dBm ±0.5dBm
-50dBm Range	_____ -50dBm ±0.5dBm
10kHz to 300kHz	
+10dBm Range	_____ +10dBm ±0.2dBm
0dBm Range	_____ 0dBm ±0.2dBm
-10dBm Range	_____ -10dBm ±0.2dBm
-20dBm Range	_____ -20dBm ±0.2dBm
-30dBm Range	_____ -30dBm ±0.2dBm
-40dBm Range	_____ -40dBm ±0.2dBm
-50dBm Range	_____ -50dBm ±0.2dBm

PERFORMANCE CHECK TEST CARD (Cont'd)

<p>CARRIER 600 BAL LEVEL ACCURACY CHECK 1kHz to 150kHz</p> <p>+10dBm Range _____</p> <p>0dBm Range _____</p> <p>-10dBm Range _____</p> <p>-20dBm Range _____</p> <p>-30dBm Range _____</p> <p>-40dBm Range _____</p> <p>-50dBm Range _____</p> <p>10kHz to 100kHz</p> <p>+10dBm Range _____</p> <p>0dBm Range _____</p> <p>-10dBm Range _____</p> <p>-20dBm Range _____</p> <p>-30dBm Range _____</p> <p>-40dBm Range _____</p> <p>-50dBm Range _____</p>	<p>_____ +10dBm ±0.5dBm</p> <p>_____ 0dBm ±0.5dBm</p> <p>_____ -10dBm ±0.5dBm</p> <p>_____ -20dBm ±0.5dBm</p> <p>_____ -30dBm ±0.5dBm</p> <p>_____ -40dBm ±0.5dBm</p> <p>_____ -50dBm ±0.5dBm</p> <p>_____ +10dBm ±0.2dBm</p> <p>_____ 0dBm ±0.2dBm</p> <p>_____ -10dBm ±0.2dBm</p> <p>_____ -20dBm ±0.2dBm</p> <p>_____ -30dBm ±0.2dBm</p> <p>_____ -40dBm ±0.2dBm</p> <p>_____ -50dBm ±0.2dBm</p>																																																																																												
<p>VF/Nm 600 BAL and 900 BAL LEVEL ACCURACY CHECK 20Hz to 20kHz</p> <p>0dBm Range _____</p> <p>-10dBm Range _____</p> <p>-20dBm Range _____</p> <p>-30dBm Range _____</p> <p>-40dBm Range _____</p> <p>-50dBm Range _____</p> <p>-60dBm Range _____</p> <p>-70dBm Range _____</p> <p>-80dBm Range _____</p> <p>40Hz to 1SkHz</p> <p>0dBm Range _____</p> <p>-10dBm Range _____</p> <p>-20dBm Range _____</p> <p>-30dBm Range _____</p> <p>-40dBm Range _____</p> <p>-50dBm Range _____</p> <p>-60dBm Range _____</p> <p>100Hz to 20kHz</p> <p>+30dBm Range _____</p> <p>+20dBm Range _____</p> <p>+10dBm Range _____</p> <p>100Hz to 15kHz</p> <p>+30dBm Range _____</p> <p>+20dBm Range _____</p> <p>+10dBm Range _____</p>	<table border="0"> <thead> <tr> <th></th> <th>600 ohms</th> <th>900 ohms</th> <th></th> </tr> </thead> <tbody> <tr> <td>_____</td> <td>_____</td> <td>_____</td> <td>0dBm ±0.5dBm</td> </tr> <tr> <td>_____</td> <td>_____</td> <td>_____</td> <td>-10dBm ±0.5dBm</td> </tr> <tr> <td>_____</td> <td>_____</td> <td>_____</td> <td>-20dBm ±0.5dBm</td> </tr> <tr> <td>_____</td> <td>_____</td> <td>_____</td> <td>-30dBm ±0.5dBm</td> </tr> <tr> <td>_____</td> <td>_____</td> <td>_____</td> <td>-40dBm ±0.5dBm</td> </tr> <tr> <td>_____</td> <td>_____</td> <td>_____</td> <td>-50dBm ±0.5dBm</td> </tr> <tr> <td>_____</td> <td>_____</td> <td>_____</td> <td>-60dBm ±0.5dBm</td> </tr> <tr> <td>_____</td> <td>_____</td> <td>_____</td> <td>-70dBm ±0.5dBm</td> </tr> <tr> <td>_____</td> <td>_____</td> <td>_____</td> <td>-80dBm ±0.5dBm</td> </tr> <tr> <td>_____</td> <td>_____</td> <td>_____</td> <td>0dBm ±0.2dBm</td> </tr> <tr> <td>_____</td> <td>_____</td> <td>_____</td> <td>-10dBm ±0.2dBm</td> </tr> <tr> <td>_____</td> <td>_____</td> <td>_____</td> <td>-20dBm ±0.2dBm</td> </tr> <tr> <td>_____</td> <td>_____</td> <td>_____</td> <td>-30dBm ±0.2dBm</td> </tr> <tr> <td>_____</td> <td>_____</td> <td>_____</td> <td>-40dBm ±0.2dBm</td> </tr> <tr> <td>_____</td> <td>_____</td> <td>_____</td> <td>-50dBm ±0.2dBm</td> </tr> <tr> <td>_____</td> <td>_____</td> <td>_____</td> <td>-60dBm ±0.2dBm</td> </tr> <tr> <td>_____</td> <td>_____</td> <td>_____</td> <td>+30dBm 0±0.5dBm</td> </tr> <tr> <td>_____</td> <td>_____</td> <td>_____</td> <td>+20dBm ±0.5dBm</td> </tr> <tr> <td>_____</td> <td>_____</td> <td>_____</td> <td>+10dBm ±0.5dBm</td> </tr> <tr> <td>_____</td> <td>_____</td> <td>_____</td> <td>+30dBm ±0.2dBm</td> </tr> <tr> <td>_____</td> <td>_____</td> <td>_____</td> <td>+20dBm ±0.2dBm</td> </tr> <tr> <td>_____</td> <td>_____</td> <td>_____</td> <td>+10dBm ±0.2dBm</td> </tr> </tbody> </table> <p align="center">(2)</p>		600 ohms	900 ohms		_____	_____	_____	0dBm ±0.5dBm	_____	_____	_____	-10dBm ±0.5dBm	_____	_____	_____	-20dBm ±0.5dBm	_____	_____	_____	-30dBm ±0.5dBm	_____	_____	_____	-40dBm ±0.5dBm	_____	_____	_____	-50dBm ±0.5dBm	_____	_____	_____	-60dBm ±0.5dBm	_____	_____	_____	-70dBm ±0.5dBm	_____	_____	_____	-80dBm ±0.5dBm	_____	_____	_____	0dBm ±0.2dBm	_____	_____	_____	-10dBm ±0.2dBm	_____	_____	_____	-20dBm ±0.2dBm	_____	_____	_____	-30dBm ±0.2dBm	_____	_____	_____	-40dBm ±0.2dBm	_____	_____	_____	-50dBm ±0.2dBm	_____	_____	_____	-60dBm ±0.2dBm	_____	_____	_____	+30dBm 0±0.5dBm	_____	_____	_____	+20dBm ±0.5dBm	_____	_____	_____	+10dBm ±0.5dBm	_____	_____	_____	+30dBm ±0.2dBm	_____	_____	_____	+20dBm ±0.2dBm	_____	_____	_____	+10dBm ±0.2dBm
	600 ohms	900 ohms																																																																																											
_____	_____	_____	0dBm ±0.5dBm																																																																																										
_____	_____	_____	-10dBm ±0.5dBm																																																																																										
_____	_____	_____	-20dBm ±0.5dBm																																																																																										
_____	_____	_____	-30dBm ±0.5dBm																																																																																										
_____	_____	_____	-40dBm ±0.5dBm																																																																																										
_____	_____	_____	-50dBm ±0.5dBm																																																																																										
_____	_____	_____	-60dBm ±0.5dBm																																																																																										
_____	_____	_____	-70dBm ±0.5dBm																																																																																										
_____	_____	_____	-80dBm ±0.5dBm																																																																																										
_____	_____	_____	0dBm ±0.2dBm																																																																																										
_____	_____	_____	-10dBm ±0.2dBm																																																																																										
_____	_____	_____	-20dBm ±0.2dBm																																																																																										
_____	_____	_____	-30dBm ±0.2dBm																																																																																										
_____	_____	_____	-40dBm ±0.2dBm																																																																																										
_____	_____	_____	-50dBm ±0.2dBm																																																																																										
_____	_____	_____	-60dBm ±0.2dBm																																																																																										
_____	_____	_____	+30dBm 0±0.5dBm																																																																																										
_____	_____	_____	+20dBm ±0.5dBm																																																																																										
_____	_____	_____	+10dBm ±0.5dBm																																																																																										
_____	_____	_____	+30dBm ±0.2dBm																																																																																										
_____	_____	_____	+20dBm ±0.2dBm																																																																																										
_____	_____	_____	+10dBm ±0.2dBm																																																																																										

PERFORMANCE CHECK TEST CARD (Cont'd)

RETURN LOSS CHECK VF/Nm 30Hz to 20kHz CARRIER 600 ohms, 1kHz to 150kHz 135 ohms, 1kHz to 600kHz 75 ohms, 1kHz to 3MHz	600 ohms	900 ohms	
	_____	_____	>30dB
	_____	_____	>26dB
	_____	_____	> 26dB
	_____	_____	>30dB
FILTER RESPONSE CHECKS C-MSG 60Hz 200Hz 500Hz 1kHz 2kHz 2.5kHz 4kHz 5kHz 3kHz FLAT 60Hz 250Hz 1kHz 2kHz 2.5kHz 3kHz 15kHz FLAT 60Hz 250Hz 1kHz 5kHz 10kHz 12.5kHz 15kHz PROGRAM			_____ -55.7dBm ±2dBm _____ -25dBm ±2dBm _____ -7.5dBm ±1dBm _____ 0dBm (Ref) _____ -1.3dBm ±1dBm _____ -1.4dBm ±2dBm _____ -14.5dBm ±3dBm _____ -28.5dBm ±3dBm _____ 0dBm ±1.75dBm _____ 0dBm ±1dBm _____ 0dBm (Ref) _____ -0.5dBm ±1.75dBm _____ -1.5dBm ±2dBm _____ -3dBm ±3dBm _____ 0dBm ±1.75dBm _____ 0dBm ±1dBm _____ 0dBm (Ref) _____ 0dBm ±1dBm _____ -0.5dBm ±1.75dBm _____ -1.5dBm ±2dBm _____ -3dBm ±3dBm
200Hz 500Hz 1kHz 2kHz 4kHz 5kHz 6kHz 8kHz 10kHz BRIDGING LOSS CHECK			_____ -17.3dBm ±2dBm _____ -6.6dBm ±1dBm _____ 0dBm (Ref) _____ +4.8dBm ±2dBm _____ +6.5dBm ±2dBm _____ +6.5dBm ±2dBm _____ +6.4dBm ±3dBm _____ +4dBm ±3dBm _____ -8.5dBm ±4dBm
VF/Nm 900 BAL, 1kHz VF/Nm 600 BAL, 1kHz CARRIER 600 BAL, 10kHz INPUT BALANCE CHECK VF/Nm 600 BAL			_____ 0.3dBm _____ <0.3dBm _____ <.05dBm
60Hz 6kHz 20kHz CARRIER 600 BAL 1kHz to 10kHz 1kHz to 100kHz 1kHz to 600kHz			_____ >80dB _____ >70dB _____ >50dB _____ >70dB _____ >60dB _____ >40dB

**SECTION VI
REPLACEABLE PARTS**

6-1. INTRODUCTION.

6-2. This section contains information for ordering replacement parts. Table 6-1 lists parts in alphameric order of their reference designators and indicates the description, -hp- part number of each part, together with any applicable notes, and provides the following:

- a. Total quantity used in the instrument (TQ column). The total quantity of a part is given the first time the part number appears.
- b. Description of the part. (See list of abbreviations below.)

- c. Typical manufacturer of the part in a five-digit code. (See Appendix A for list of manufacturers.)
- d. Manufacturer's part number.

6-3. Miscellaneous parts are listed at the end of Table 6-1.

6-4. ORDERING INFORMATION.

6-5. To order a part, note the manufacturer's part number (Table 6-1, MFR PART NO.) and then cross reference that number in the cross-reference index (Table 6-2). Order the part through normal channels. If the NSN is not listed for the part in Table 6-2, order by MFR PART NO. and the manufacturer's identification number listed under the MFR number in Table 6-1.

Ag..... silver
 Al..... aluminum
 A..... incandescent
 Au..... gold

 C..... capacitor
 cer..... ceramic
 coef..... coefficient
 com..... common
 comp..... composition
 conn..... connection

 dep..... deposited
 DPDT..... double-pole double-throw
 DPST..... double-pole single-throw

 elect..... electrolytic
 encap..... encapsulated

 F..... farad(s)
 FET..... field effect transistor
 fxd..... fixed

 GaAs..... gallium arsenide
 GHz..... gigahertz = 10⁺⁹ hertz
 gd..... guard(ed)
 Ge..... germanium
 grd..... ground(ed)

 H..... henry(ies)
 Hg..... mercury
 Hz..... hertz (cycle(s) per second)

ID..... inside diameter
 impg..... impregnated
 incd..... incandescent
 ins..... insulation(ed)

 kΩ..... kilohm(s) = 10⁺³ ohms
 kHz..... kilohertz = 10⁺³ hertz

 L..... inductor
 lin..... linear taper
 log..... logarithmic taper

 mA..... milliampere(s) = 10⁻³ amperes
 MHz..... megahertz = 10⁺⁶ hertz
 mΩ..... megohm(s) = 10⁺⁶ ohms
 met film..... metal film
 mfr..... manufacturer
 ms..... millisecond
 mtg..... mounting
 mV..... millivolt(s) = 10⁻³ volts
 μF..... microfarad(s)
 μs..... microsecond(s)
 μV..... microvolt(s) = 10⁻⁶ volts
 my..... Mylar®

 nA..... nanoampere(s) = 10⁻⁹ amperes
 NC..... normally closed
 Ne..... neon
 NO..... normally open
 NPO..... negative positive zero
 (zero temperature coefficient)

ABBREVIATIONS

ns..... nanosecond(s) = 10⁻⁹ seconds
 nar..... not separately replaceable

 Ω..... ohm(s)
 obd..... order by description
 OD..... outside diameter

 P..... peak
 Pa..... picoampere(s)
 pc..... printed circuit
 pF..... picofarad(s) 10⁻¹²
 farads
 piv..... peak inverse voltage
 p/o..... part of
 pos..... position(s)
 poly..... polyesterene
 pot..... potentiometer
 p-p..... peak-to-peak
 ppm..... parts per million
 prec..... precision (temperature
 coefficient, long term sta-
 bility, and/or tolerance)

 R..... resistor
 Rh..... rhodium
 rms..... root-mean-square
 rot..... rotary

 Se..... selenium
 sect..... section(s)
 Si..... silicon
 sl..... slide

SPDT..... single-pole double-throw
 SPST..... single-pole single-throw

 Ta..... tantalum
 TC..... temperature coefficient
 TiO₂..... titanium dioxide
 tog..... toggle
 tol..... tolerance
 trim..... trimmer
 TSTR..... transistor

 V..... volt(s)
 vacw..... alternating current
 working voltage
 var..... variable
 vdcw..... direct current working voltage

 W..... watt(s)
 w/..... with
 wiv..... working inverse voltage
 w/o..... without
 ww..... wirewound

 *..... optimum value selected at
 factory, average value
 shown (part may be omitted)
 **..... no standard type number
 assigned (selected or
 special type)

© Dupont de Nemours

DECIMAL MULTIPLIERS

Prefix	Symbols	Multiplier	Prefix	Symbols	Multiplier
tera	T	10 ¹²	centi	c	10 ⁻²
giga	G	10 ⁹	milli	m	10 ⁻³
mega	M or Meg	10 ⁶	micro	μ	10 ⁻⁶
kilo	K or k	10 ³	nano	n	10 ⁻⁹
hecto	h	10 ²	pico	p	10 ⁻¹²
deka	da	10	femto	f	10 ⁻¹⁵
deci	d	10 ⁻¹	atto	a	10 ⁻¹⁸

DESIGNATORS

A..... assembly
 B..... motor
 BT..... battery
 C..... capacitor
 CT..... diode
 DL..... delay line
 DS..... lamp
 E..... misc electronic part
 F..... fuse

FL..... filter
 HR..... heater
 IC..... integrated circuit
 J..... jack
 K..... relay
 L..... inductor
 M..... meter
 MP..... mechanical part
 P..... plug

Q..... transistor
 QCR..... transistor-diode
 R..... resistor
 RT..... thermistor
 S..... switch
 T..... transformer
 TB..... terminal board
 TC..... thermocouple
 TP..... test point

TS..... terminal strip
 V..... vacuum tube, neon bulb
 photocell, etc.
 W..... cable
 X..... socket
 XDS..... lampholder
 XF..... fuseholder
 Y..... crystal
 Z..... network

Table 6-1. Replaceable Parts

REFERENCE DESIGNATOR	-hp- PART NO.	TQ	DESCRIPTION	MFR.	MFR. PART NO.
A1	03555-66507	1	PC Board Ass'y: function	-hp-	
C1	0170-0055	1	C: fxd mylar 0.1uF +/-20% 200 vdcw	56289	192P10402-PTS
C2,C3	0180-0089	2	C: fxd Al elect 10uF +50% -10% 150 vdcw	56289	30D106F150DD2-DSM
C4	0121-4105	3	C: var 9-35pF	72982	538-00694D
C5*	0160-0205	2	C: fxd mica 10pF +/-5%	72136	RDM15C100J5S
C6	0160-2206	1	C: fxd mica 160pF +/-5%	72136	RDM15F161J3C
C7	0121-0105		C: var 9-35pF	72982	53830694D
C8*	0140-0204	1	C: fxd mica 47pF +/-5%	72136	DM15E470J0500W1CR
C9*	0140-0193	1	C: fxd mica 82pF +/-5%	72136	RDM15E82OJ3C
C10	0160-0763	1	C: fxd mica 5pF 10%	14655	RDM15C050K5S
R1	0698-0090	2	R: fxd met flm 464 ohms +/-1% 1/2W	91637	MFF-1/2-T-1
R2	0811-2846	2	R: fxd ww 300 ohms +/-1% 1/2W	-hp-	
R3	0684-2211	3	R: fxd comp 220 ohms +/-10% 1/4W	01121	CB2211
R4	0811-2847	2	R: fxd ww 67.5 ohms +/-1% 1/2W	-hp-	
R5,R6	0698-3499	2	R: fxd met flm 40.2 kilohms +/-1% 1/8W	91637	MF-1/10-32
R7	0698-4508	1	R: fxd met flm 78.7 kilohms +/-1% 1/8W	14674	C4
R8	0698-4467	1	R: fxd met flm 1.05 kilohms +/-1% 1/8W	91637	MF-1/10-32
R9	0698-0090		R: fxd met flm 464 ohms +/-1% 1/2W	91637	MFF-1/2-T-1
R10	0811-2846		R: fxd ww 300 ohms +/-1% 1/2W	-hp-	
R11	0684-2211		R: fxd comp 220 ohms +/-10% 1/4W	01121	CB2211
R12*	0684-4711	1	R: fxd comp 470 ohms +/-10% 1/4W	01121	CB4711
R13	0811-2794	1	R: fxd prec ww 25 kilohms 5%	-hp-	
R14*	0684-2211		R: fxd comp 220 ohms +/-10% 1/4W	01121	CB2211
R15	0757-0472	3	R: fxd met flm 200 kilohms +/-1% 1/8W	75042	CEA
R16	0811-2847		R: fxd ww 67.5 ohms +/-1% 1/2W	-hp-	
R17	0683-1505	1	R: fxd 15 ohms +/-5% 1/4W	01121	CB1505
S1	3100-1793	1	Switch Ass'y: pushbutton	71590	1332
T1	9100-1458	1	Transformer: carrier frequency	-hp-	
T2	9100-1460	1	Transformer: audio	-hp-	
W1	03555-61616	1	Cable Ass'y: function	-hp-	
A2	03555-66509	1	PC Board Ass'y: range switch	-hp-	
C1	0121-0128	4	C: var 1.4-9.2pF air trim	74970	189-503-5
C2	0160-0196	2	C: fxd mica 24pF +/-5%	72136	RDM15C240J3S
C3	0160-2130	4	C: fxd mica 865pF +/-1% 100 vdcw	72136	RDM15F(865)F1C
C4	0121-0128		C: var 1.49.2pF air trim	74970	189-503-5
C5	0160-0196		C: fxd mica 24pF +/-5%	72136	RDM15C240J3S
C6	0160-2130		C: fxd mica 865pF +/-1% 100 vdcw	72136	RDM15F(865)F1C
C7	0121-0128		C: var 1.4-9.2pF air trim	74970	189-503-5
†C8	0160-2307	1	C: fxd mica 47pF 5%	00853	RDM15E470J3C
†C9	0160-3482	1	C: fxd mica 430pF 1% 300 vdcw	14655	RDM15F431F3C
†C10	0160-3586	1	C: fxd mica 43pF 300 vdcw	72136	RDM15E4300D3C
†C11	0160-3083	1	C: fxd mica 62pF 1% 500 V	72136	RDM15D620F5C
C12	0121-0128		C: var 1.4-9.2pF air trim	74970	189-503-5
R1	0698-7330	2	R: fxd flm 96.84 kilohms +/-0.1% 1/8W	91637	CMF-1/10-32
R2	0698-7329	2	R: fxd met firm 3.266 kilohms +/-0.1% 1/8W	91637	CMF-1/10-32
R3	0684-2701	2	R: fxd comp 27 ohms +/-1-10% 1/4W	01121	CB2701
R4	0698-7330		R: fxd flm 96.84 kilohms +/-0.1% 1/8W	91637	CMF-1/10-32
R5	0698-7329		R: fxd met firm 3.266 kilohms +/-0.1% 1/8W	91637	CMF-1/10-32

† See backdating in Appendix C.

Table 6-1. Replaceable Parts (Cont'd)

REFERENCE DESIGNATOR	-hp- PART NO.	TQ	DESCRIPTION	MFR.	MFR. PART NO.	
A2 (Cont'd)						
R6	0683-1805	1	R: fxd comp 18 ohms +/-5% 1/4W	01121	CB1805	
R7	0698-4342	1	R: fxd met flm 90 kilohms +/-0.1% 1/8W	91637	MF-1/10-32	obd
R8	0698-4339	1	R: fxd met flm 11.11 kilohms +/-0.1% 1/8W'	91637	MF-1/10-32	obd
R9	0698-5095	1	R: fxd carbon comp 12 ohms +/-10% 1/2W	01121	CB1201	
R10	0698-7328	1	R: fxd met flm 68.38 kilohms +/-0.1% 1/8W	91637	MF-1/10-32	obd
R11	0698-7331	1	R: met flm 46.28 kilohms +/-0.1% 1/8W	91637	MF-1/10-32	obd
R12			Not assigned			
R13	0698-3150	1	R: fxd met flm 2.37 kilohms +/-1% 1/8W	91637	MF-1/10 2	obd
R14	0698-3264	1	R: fxd met flm 11.8 kilohms +/-1% 1/8W	14674	C4	obd
S1	3100-1791	1	Switch: rotary range	76854	1332	obd
A3	03555-66508	1	Board Ass'y: amplifier	-hp-		
C1*	0160-0763	2	C: fxd mica 5pF +/-10%	72136	RDM15COFOKSS	
C2	0180-0197	5	C: fxd Ta 2.2uF +/-10% 20 vdcw	56289	150D225X9020A2-DYS	
C3	0180-1746	4	C: fxd Ta elect 15uF +/-10% 20 vdcw	56289	150D156X9020B2-DYS	
C4	0160-2964	6	C: fxd cer 0.01uF +80% -20% 25 vdcw	72982	5835000.Y5UO-10 32	
C5	0160-0205		C: fxd mica 10pF +/-5%	72136	RDM15C100J58S	
C6,C7	0160-0378	2	C: fxd mica 27pF +/-5%	72136	RDM15E27OJ5S	
C8	0121-0105		C: var 9-35pF	72982	538400694D	
C9	0140-0196	1	C: fxd mica 150pF +/-5%	72136	RDM15F151J3C	
C10	0180-0228	10	C: fxd Ta elect 22uF +/-10% 15 vdcw	37942	TAS226K015P1C	
C11	0180-0106	1	C: fxd Ta 60uF +/-20% 6 vdcw	56289	90803	
C12 thru C14	0160-2964		C: fxd cer 0.01uF +80% -20% 25 vdcw	72982	5835000)Y5U-1032	
C15*	0180-0228		C: fxd Ta elect 22uF +/-10% 15 vdcw	37942	TAS226K015P1C	
C16	0180-0393	3	C: fxd Ta elect 39uF +/-10% -10 vdcw	37942	TAS396KO10PIC	
C17	0160-2964		C: fxd cer 0.01uF +80% -20% 25 vdcw	72982	5835000.Y5UO-1032	
C18			Not assigned			
C19	0180-0197		C: fxd Ta 2.2uF +/-10% 20 vdcw	56289	150D225X9020A2-DYS	
C20	0160-0763		C: fxd mica 5pF +/-10%	72136	RDM15C050K5SS	
C21	0180-1702	1	C: fxd Ta elect 180uF +/-20% 6 vdcw	37942		obd
C22	0160-2964		C: fxd cer 0.01uF +80% -20% 25 vdcw	72982	5835-000-Y5UO-1032	
C23	0180-0197		C: fxd Ta 2.2uF +/-10% 20 vdcw	56289	150D225X9020A2-DYS	
C24	0180-0137	1	C: fxd Ta 100uF +/-20% 10 vdcw	56289	150D107X0010R2-DYS	
C25	0180-0197		C: fxd Ta 2.2uF +/-10% 20 vdcw	56289	150D225X9020A2-DYS	
C26	0150-0011	1	C: fxd TiO2 1.5pF +/-20% 500 vdcw	78488	Type GA	obd
C27	0180-0393		C: fxd Ta elect 39uF +/-10% -10 vdcw	37942	TAS396KO10P1C	
C28	0180-0196	1	C: fxd Ta 56uF +/-10% 15 vdcw	37942	TAS566K015P F	
C29	0180-0374	1	C: fxd Ta elect 10uF +/-10% 20 vdcw	37942	TAS106K020F1C	
C30 thru C32	0180-0228		C: fxd Ta elect 22uF +/-10% 15 vdcw	37942	TAS226K015PIC	
C33	0180-0197		C: fxd Ta 2.2uF +/-10% 20 vdcw	56289	150D225X9020A2-DYS	
C34	0180-1794	1	C: fxd Ta elect 22uF +/-10% 35 vdcw	56289	150D226X9035R2-DYS	
C35 thru C37	0180-1746		C: fxd Ta elect 15uF +/-10% 20 vdcw	56289	150D156X9020B2-DYS	
CR1,CR2	1901-0376	2	Diode: Si 35 wiv 2pF	07933	RD5288	
CR3,CR4	1902-3030	4	Diode: zener 3.01V +/-5% 400mW 20mA	04713	SZ10939-32	
CR5 thru CR7	1901-0040	11	Diode: Si 30 wiv 2pF 30mA 2ns	07263	FDG1088	
CR8	1902-0761	3	Diode: zener 6.2V +/-5% 400mW 7.5mA	04713	Type 1N821	
CR9	1902-3030		Diode: zener 3.01V +/-5% 400mW 20mA	04713	SZ1Q939-32	
CR10	1901-0040		Diode: Si 30 wiv 2pF 30mA 2ns	07263	FDG10B8	
CR11	1902-3030		Diode: zener 3.01V +/-5% 400mW 20mA	04713	SZ10939-32	
CR12,CR13	1901-0040		Diode: Si 30 wiv 2pF 30mA 2ns	07263	FDG1088	
CR14	1902-0761		Diode: zener 6.2V +/-5% 400mW 7.5mA	04713	Type 1N821	
CR15,CR16	1901-0040		Diode: Si 30 wiv 2pF 30mA 2ns	07263	FDG1088	
CR17	1901-0025	7	Diode: Si 100 wiv 12pF 10mA	24446	SS410	
CR18,CR19	1901-0040		Diode: Si 30 wiv 2pF 30mA 2ns	07263	FDG10O88	

Table 6-1. Replaceable Parts (Cont'd)

REFERENCE DESIGNATOR	-hp- PART NO.	TQ	DESCRIPTION	MFR.	MFR. PART NO.	
A3 (Cont'd)						
CR20	1902-1275		Diode: zener 6.2V +/-5% 400mW 7.5mA	04713	Type 1N821	
CR21	1901 0040		Diode: Si 30 wiv 2pF 30mA 2ns	07263	FDG1088	
K1 thru K3	0490-0780	3	Relay Ass'y: reed	-hp-		
	0490-0778	3	Reeds	95348	MR5830	
L1	9100-1637	1	Inductor: fxd 120uH +/-5%	82142	15-1315-14J	
Q1	1853-0086	7	TSTR: Si PNP 2N5087	04713	SPS-3322	
Q2, Q3	1853-0036	9	TSTR: Si PNP 2N3906	04713	SPS-3612	
Q4	1854-0215	3	TSTR: Si NPN 2N3904	04713	SPS-3611	
Q5 thru Q8	1853-0036		TSTR: Si PNP 2N3906	04713	SPS-3612	
Q9	1854-0215		TSTR: Si NPN 2N3904	04713	SPS-3611	
Q10	1853-0036		TSTR: Si PNP 2N3906	04713	SPS-3612	
Q11	1855-0057	1	TSTR: Si FET N channel Type A	04713	SS-3651	
Q12	1853-0036		TSTR: Si PNP 2N3906	04713	SPS-3612	
Q13	1854-0092	2	TSTR: NPN 2N3563	04713	MPS-3563	
Q14	1853-0049	2	TSTR: Si PNP	04713	-hp-	
Q15	1854-0215		TSTR: Si NPN 2N3904	04713	SPS-3611	
Q16	1853-4049		TSTR: Si PNP	04713	-hp-	
Q17	1854-0401	1	TSTR: NPN	04713	-hp-	
Q18,Q19	1853-0235	3	TSTR: Si PNP 2N3547	12040	NS62048	
Q20	1854-0022	1	TSTR: NPN	01295	SG1294	
Q21	1853-0235		TSTR: Si PNP 2N3547	12040	NS62048	
Q22	1853-0037	1	TSTR: Si PNP	04713	2N2904A	
R1	0757-0334	1	R: fxd met flm 301 ohms +/-1% 1/4W	91637	MF-1/8-44	obd
R2	0698-4521	2	R: fxd met flm 154 kilohms +/-1% 1/8W	14674	C4	obd
R3	0698-4533	1	R: fxd met flm 294 kilohms +/-1% 1/8W	14674	C4	obd
R4	0684-4731	2	R: fxd comp 47 kilohms +/-10% 1/4W	01121	CB4731	
R5	0684-1221	2	R: fxd comp 1.2 kilohms +/-10% 1/4W	01121	CB1221	
R6	0684-1011	5	R: fxd comp 100 ohms +/-10% 1/4W	01121	CB1011	
R7,R8	0684-2241	2	R: fxd comp 220 kilohms +/-10% 1/4W	01121	C82241	
R9	0684-4721	3	R: fxd comp 4700 ohms +/-10% 1/4W	01121	CB4721	
R10	0684-1011		R: fxd comp 100 ohms +/-10% 1/4W	01121	CB1011	
R11	0698-7375	3	R: fxd met flm 28.64 kilohms +/-0.1% 1/8W	91637	CMF-1/10-32	obd
R12	0684-1011		R: fxd comp 100 ohms +/-10% 1/4W	01121	CB1011	
R13,R14	0757-0273	2	R: fxd met flm 3.01 kilohms +/-1% 1/8W	91637	MF-1/10-32	obd
R15	2100-2829	1	R: var carbon comp 500 ohms +/-30% 1/4W 4 sec type V	71590	Type E8-83716	
R16	0698-4458	1	R: fxd met flm 590 ohms +/-1% 1/8W	14674	C4	obd
R17	0684-1011		R: fxd comp 100 ohms +/-10% 1/4W	01121	CB1011	
R18	0684-1041	1	R: fxd comp 100 kilohms +/-10% 1/4W	01121	CB1041	
R19	0698-3154	1	R: fxd met flm 4.22 kilohms +/-1% 1/8W	91637	MF-1/10-32	obd
R20	2100-2829		R: var carbon comp 5 kilohms +/-30%	71590	Type E8-83716	
R21	0698-3155	1	R: fxd metflm 4.64 kilohms +/-1% 1/8W	91637	MF-1/10-32	obd
R22	0698-4405	1	R: fxd met flm 107 ohms +/-1% 1/8W	14674	C4	obd
R23	0684-2221	1	R: fxd comp 2200 ohms +/-10% 1/4W	01121	CB2221	
R24	2100-2829		R: var carbon comp 500 ohms +/-30%	71590	Type E8-83716	
R25	0698-4014	1	R: fxd met flm 787 ohms +/-1% 1/8W	14674	C4	obd
R26	2100-2829		R: var carbon comp 500 ohms +/-30%	71590	Type E883716	
R27	0698-4521		R: fxd met flm 154 kilohms +/-1% 1/8W	14674	C4	obd
R28,R29			Not assigned			
R30	0684-3341	1	R: fxd comp 330 kilohms +/-10% 1/4W	01121	CB3341	
R31	0684-1541	3	R: fxd comp 150 kilohms +/-10% 1/4W	01121	CB1541	
R32	0684-1011		R: fxd comp 100 ohms +/-10% 1/4W	01121	CB1011	
R33	0684-1221		R: fxd comp 1.2 kilohms +/-10% 1/4W	01121	CB1221	
R34	0684-1021	6	R: fxd comp 10000 ohms +/-10% 1/4W	01121	C81021	
R35,R36	0684-1541		R: fxd comp 150 kilohms +/-10% 1/4W	01121	CB1541	
R37	0684-4721		R: fxd comp 4700 ohms +/-10% 1/4W	01121	C84721	
R38	0698-4454	1	R: fxd met flm 523 ohms +/-1% 1/8W	91637	MF-1/10-32	obd
R39	0684-3921	3	R: fxd comp 3900 ohms +/-10% 1/4W	01121	CB3921	

Table 6-1. Replaceable Parts (Cont'd)

REFERENCE DESIGNATOR	-hp- PART NO.	TQ	DESCRIPTION	MFR.	MFR. PART NO.	
A3 (Cont'd)						
R40	0684 4721		R: fxd comp 4700 ohms +/-10% 1/4W	01121	CB4721	
R41,R42	0698-3382	2	R: fxd met flm 5.49 kilohms +/-1% 1/8W	91637	MF-1/10-32	obd
R43	2100-1770	1	R: var ww 00 ohm +/-100% 1/2W trimmer	80294	3-365P-E88-101	
R44	0698-3223	1	R: fxd met flm 1.24 kilohms +/-1% 1/8W	91637	MF-1/10-32	obd
R45	0684-2231	3	R: fxd comp 22 kilohms +/-10% 1/4W	01121	CB2231	
R46*	0684-3921		R: fxd comp 3900 ohms +/-10% 1/4W	01121	CB3921	
R47	0684-8211	2	R: fxd comp 820 ohms +/-10% 1/4W	01121	CB8211	
R48	0684-2231		R: fxd comp 22 kilohms +/-10% 1/4W	01121	CB2231	
R49	0757-4442	3	R: fxd met flm 10 kilohms +/-1% 1/8W	91637	MF-1/10-32	obd
R50	0684-1031	2	R: fxd comp 10 kilohm +/-10% 1/4W	01121	CB1031	
R51	0084-8211		R: fxd comp 820 ohm +/-10% 1/4W	01121	CB8211	
R52	0767-0280		R: fxd met flm 1 kilohm +/-1% 1/8W	91637	CMF-1/10-32	obd
R53,R54	0684-1211	2	R: fxd comp 120 ohm +/-10% 1/4W	01121	CB1211	
R55	0757-0442		R: fxd met flm 10 kilohms +/-1% 1/8W	91637	MF-1/10-32	obd
R56 thru R58			Not assigned			
R59	0757-4468	1	R: fxd met flm 130 kilohm +/-1% 1/8W	14674	C4	obd
R60	0684-3331	1	R: fxd comp 33 kilohms +/-10% 1/4W	01121	CB3331	
R61	0684-1001	3	R: fxd comp 10 ohm +/-100% 1/4W	01121	CB1001	
R62	0684-3921		R: fxd comp 3900 ohms +/-10% 1/4W	01121	CB3921	
R63	0684-1031		R: fxd comp 10 kilohms +/-100 1/4W	01121	CB1031	
R64	0684-2231		R: fxd comp 22 kilohms +/-10% 1/4W	01121	CB2231	
R65 thru R67	0684-1021		R: fxd comp 1000 ohms +/-10% 1/4W	01121	CB1021	
R68	0698-4503	1	R: fxd met flm 66.5 kilohms +/-1% 1/8W	91637	MF-1/10-32	obd
R69	0698-4491	1	R: fxd met flm 30.9 kilohms +/-1% 1/8W	91637	MF-1/10-32	obd
R70,R71	06841001		R: fxd comp 10 ohm +/-10% 1/4W	01121	CBI001	
R72*	0684-2701		R: fxd comp 27 ohm +/-10% 1/4W	01121	CB2701	
R73	0684-1021		R: fxd comp 1000 ohm +/-10% 1/4W	01121	CB1021	
R74*,R75*	0684-8221	2	R: fxd comp 8200 ohm +/-10% 1/4W	01121	CB8221	
XA1	1251-1941	1	Connector: PC 6 pin	71785	252-06-30-310	
W1	0355-61616	1	Cable	-hp-		
A4	03555-66506	1	PC Board Ass'y: filter	-hp-		
C1	0140-0177	1	C: fxd mica 400pF +/-1%	72136	RDM15F3C	
C2	0180-0291	4	C: fxd Ta elect 1uF +/-10% 35 vdcw	56289	150D105X9035A2-DYS	
C3,C4	0160-2130		C: fxd mice 865pF +/-1% 100 vdcw	72136	RDM15F(865)F1C	
C5	0140-0203	5	C: fxd mica 30pF +/-5%	72136	RDM15F421F3C	
C6	0180-0228		C: fxd elect 22uF +/-10% 15 vdcw	37942	TAS226K015PIC	
C7	0140-0163	6	C: fxd mice 4751pF +/-1% 300 vdcw	72136	RDM20F(4751)F3S	
C8	0160-3024	4	C: fxd mica 1700pF +/-1% 100 vdcw	72136	RDM19F 72F1S	
C9	0140-0203		C: fxd mice 30pF +/-5%	72138	RDM15F421F3C	
C10	0160-3024		C: fxd mice 1700pF +/-1% 100 vdcw	72138	RDM19F172F1S	
C11	0180-0228		C: fxd Ta elect 22uF +/-10% 15 vdcw	37942	TAS226K01PIC	
C12	0140-0163		C: fxd mica 4751pF +/-1% 300 vdcw	72136	RDM20F(4751)F3S	
C13 thru C15			Not assigned			
C16	0160-3024		C: fxd mice 1700pF +/-1% 100 vdcw	72136	RDM19F172F1S	
C17	0140-0203		C: fxd mica 30pF +/-5%	72136	RDM15F421F3C	
C18	0160-3024		C: fxd mica 1700pF +/-1% 100 vdcw	72136	RDM19F172F1S	
C19	0180-0228		C: fxd Ta elect 22uF +/-10% 15 vdcw	37942	TAS226K015PIC	
C20,C21	0180-0291		C: fxd Ta elect 1uF +/-10% 35 vdcw	56289	150D105X9035A2-DYS	
C22			Not assigned			
C23	0180-0197		C: fxd Ta 2.2uF +/-10% 20 vdcw	56289	150D225X9020A2-DYS	
C24	0140-0163		C: fxd mica 4751pF +/-1% 300 vdcw	72136	RDM20F(4751)F3S	
C25	0140-0203		C: fxd mice 30pF +/-5%	72136	RDM15F421F3C	
C26	0140-0163		C: fxd mice 4751pF +/-1% 300 vdcw	72136	RDM20F(4751)F3S	
C27	0180-0228		C: fxd Ta elect 22uF +/-10% 15 vdcw	37942	TAS226K01SPIC	
C28,C29	0140-0163		C: fxd mica 4751pF +/-1% 300 vdcw	72136	RDM20F(4751)F3S	
C30	0140-0203		C: fxd mice 30pF +/-5%	72136	RDM15F421F3C	

Table 6-1. Replaceable Parts (Cont'd)

REFERENCE DESIGNATOR	-hp- PART NO.	TQ	DESCRIPTION	MFR.	MFR. PART NO.	
A4 (Cont'd)						
C31	0180-0228		C: fxd Ta elect 22uF +/-10% 15 vdcw	37942	TAS226K015P1C	
C32	0180-0291		C: fxd Ta elect 1uF +/-10% 35 vdcw	56289	150D105X9035A2-DYS	
C33	0180-0387	1	C: fxd Ta elect 47uF +/-5% 20 vdcw	37942	TAS476J020P1F	
CR1 thru CR5	1901-0026		Diode: Si 100 wiv 12pF 100mA	24446	SS410	
Q1,Q2	1854-0071	16	TSTR: Si NPN 2N3391	01296	SKA1124	
Q3	1853-0086	6	TSTR: Si PNP 2N5087	04713	SPS-3322	
Q4,Q5	1854-0071		TSTR: Si NPN 2N3391	01296	SKA1124	
Q6	1853-0086		TSTR: Si PNP 2N5087	04713	SPS-3322	
Q7,Q8	1854-0071		TSTR: Si NPN 2N3391	01296	SKA1124	
Q9	1853-0086		TSTR: Si PNP 2N5087	04713	SPS-3322	
Q10 thru Q12	1854-0071		TSTR: Si NPN 2N3391	01295	SKA1124	
Q13	1853-0086		TSTR: Si PNP 2N50B7	04713	SPS-3322	
Q14 thru Q16	1854-0071		TSTR: Si NPN 2N3391	01295	SKA1124	
Q17	1853-0086		TSTR: Si PNP 2N5087	04713	SPS-3322	
Q18 thru Q20	1854-0071		TSTR: Si NPN 2N3391	01295	SKA1124	
Q21	1853-0086		TSTR: Si PNP 2N5087	04713	SPS-3322	
Q22	1854-0071		TSTR: Si NPN 2N3391	01296	SKA1124	
R1	0757-0450	2	R: fxd et flm 22.1 kilohms +/-1% 118W	75042	CEA	obd
R2	0038-4412	1	R: fxd met flm 17.4 kilohms +/-1% 1/8W	91637	MF-1/10-32	obd
R3	2100-0406	1	R: var carbon comp 5 kilohms +/-30% 4 sec	71590	Series 5 Type 70-4	
R4	0698-7373	1	R: fxd met flm 98.941 kilohms +/-0.1% 1/8W	91637	CMF-1/10-32	obd
R5,R6	0698-7374	2	R: fxd met flm 217Jkilohms +/-0.1% 1/8W	91637	CMF-1/10-32	obd
R7(A/B/C)	1810-0027	5	R: carbon flm network 2X100K 10 kilohms +/-10%	56289	178C5	
R8	0698-7372	1	R: fxd met flm 108.94 kilohms +/-0.1% 1/8W	91637	CMF-1/10-32	obd
R9	0698-7376	1	R: fxd met flm 11.397 kilohms +/-0.1% 1/8W	91637	CMF-1/10-32	obd
R10	0698-6313	5	R: fxd met flm 20 kilohms +/-0.1% 118W	91637	CMF-1/10-32	obd
R11	0698-7375		R: fxd met flm 28.640 kilohms +/-0.1% 1/8W	91637	CMF-1/10-32	obd
R12,R13	0757-0476	2	R: fxd met flm 301 kilohms +/-1% 1/8W	14674	C4	obd
R14	0684-6821	1	R: fxd comp 6800 ohms +/-10% 1/4W	01121	CB6821	
R15	0604-4731		R: fxd comp 47 kilohms +/-10% 11/4W	01121	C84731	
R16*	0698-3557	1	R: fxd met flm 806 ohms +/-1% 1/8W	14674	C4	obd
R17	0698-3519	1	R: fxd met flm 12.4 kilohms +/-1% 1/8W	91637	MF-1/10-32	obd
R18*	0757-0443	1	R: fxd met flm 11 kilohms +/-1% 1/8W	14674	C4	obd
R19			Not assigned			
R20	0698-7375		R: fxd met flm 28.640 kilohms +/-0.1% 1/8W	91637	CMF-1/10-32	obd
R21(A/B/C)	1810-0027		R: carbon flm network 2X100K 10 kilohms +/-10%	56289	178C5	
R22	07570451	1	R: fxd met flm 24.3 kilohms +/-1% 1/8W	14674	C4	obd
R23	0757-0450		R: fxd met flm 22.1 kilohms +/-1% 1/8W	75042	CEA	obd
R24	0698-0043		R: fxd met flm 20 kilohms +/-4.1% 1/8W	91637	CMF-1/10-32	obd
R25	0638-1407	1	R: fxd met flm 44.2 kilohms +/-1% 1/8W	14674	C4	obd
R26(A/B/C)	1810-0027		R: carbon flm network 2X100K 10 kilohms +/-10%	56289	178C5	
R27	0698-7365	1	R: fxd me flm 13.394 kilohms +/-0.1% 1/8W	91637	CMF-1/10-32	obd
R28	0038 6043		R: fxd met flm 20 kilohms +/-4.1%	91637	CMF-1/1032	obd
R29	0757-0465	1	R: fxd met flm 100 kilohms +/-1% 1/8W	14674	C4	obd
R30,R31	0684-1051	3	R: fxd comp 1 megohm +/-10% 1/4W	01121	C81051	
R32	0757-0280	2	R: fxd met flm 1 kilohm +/-1% 1/8W	91637	CMF-1/10-32	obd
R33	0757-0442		R: fxd met flm 10 kilohm +/-1% 1/8W	91637	MF-1/10-32	obd
R34	0757-0448	1	R: fxd met flm 1&2 kilohms +/-1% 1/8W	91637	MF-1/10-32	obd
R35,R36	0757-0472		R: fxd met flm 200 kilohms +/-1% 1/8W	75042	CEA	obd
R37,R38	0698-7366	2	R: fxd met flm 109.64.kilohms +/-0.1% 1/8W	91637	CMF-1/10-32	obd
R39(A/B/C)	1810-0027		R: carbon flm network 2X100K 10 kilohms +/-10%	56289	178C5	
R40	0638-0043		R: fxd met flm 20 kilohm +/-1%	91637	CMF-1/10-32	obd
R41	0698-7367	1	R: fxd met flm 78.028 kilohms +/-0.1% 1/8W	91637	CMF-1/1032	obd
R42,R43	0698-7369	2	R: fxd met flm 73803 kilohms +/-0.1% 1/8W	91637	CMF-1/10-32	obd
R44(A/B/C)	1810-0027		R: carbon flm network 2X100K 10 kilohms +/-10%	56289	178C5	
R45	0698-7368	1	R: fxd met flm 36.901 kilohms +/-0.1% 1/8W	91637	CMF-1/10-32	obd
R46	0698-6943		R: fxd met flm 20 kilohms +/-0.1%	91637	CMF-1/10-32	obd

Table 6-1. Replaceable Parts (Cont'd)

REFERENCE DESIGNATOR	-hp- PART NO.	TQ	DESCRIPTION	MFR.	MFR. PART NO.
A4 (Cont'd)					
R47	0698-7370	1	R: fxd met flm 17.579 kilohms +/-0.1% 1/8W	91637	CMF-1/10-32
R48	0684-1051		R: fxd comp 1 megohm +/-10% 1/4W	01121	CB1051
R49	0684-1021		R: fxd comp 1000 ohms +/-10% 1/4W	01121	CB1021
	03565-60104	1	Chassis Ass'y: power supply	-hp-	
			CHASSIS MOUNTED COMPONENTS		
BT1	1420-0026	1	Battery: 45V	83740	No. 482
C1	0180-2230	1	C: fxd A1 elect 150uF - 10% + 100% 200 vdcw	56289	62D10046-DFP
C2	0180-0149	1	C: fxd A1 elect 65uF 60 vdcw	hp-	
C3	0180-0393		C: fxd Ta elect 39uF +/-10% -10 vdcw	37942	TAS396K010P1C
C4*	0160-0987	1	C: fxd mica 12pF +/-5%	72136	RDM15C120J5S
C5	0150-0023	1	C: fxd cer 2000oF +/-20% 1000 vdcw	56289	20C295A2-CDH
C6	0160-0195	1	C: fxd cer 1000 pF 20% 250 vac	56289	19C251A1-CDH
CR1-4	1901-0025	4	Diode: Si 100 wiv 12pF 100mA	24446	SS410
CR6	1901-0040	1	Diode: Si 30 V 50 mA	-hp-	
DS1,DS2	2140-0298	2	Neon lamp	74276	A230
F1	2110-0320	2	Fuse: 0.15A 125V Slo-Blo	71400	MDL 15/100
	1400-0085	2	Holder: fuse	75915	342004
J1	1251-2357	1	Connector: AC power cord receptacle	82389	EAC-301
J2	1251-1900	4	Jack: telephone	82389	22A
J3	1200-0163	1	Receptacle: 5 pin	74868	78PCG5
J4	1251-1144	1	Jack: telephone	82389	MT-342B
J5	1251-1143		Jack: telephone	82389	MT-332B
J6,J7	1251-0065	4	Jack: telephone	82389	MT-331
J8,J9	1510-0084	2	Binding post: red	-hp-	
J10	1510-0087	1	Binding post Ass'y	-hp-	
J11	1510-0531	1	Binding post Ass'y	-hp-	
J12,J13	1251-0065		Jack: telephone	82389	MT-331
J14	1251-1143		Jack: telephone	82389	MT-332B
J17	1250-1053	1	Jack: coaxial	70674	CJ-1010
J18	1251-1143		Jack: telephone	82389	MT-332B
L1	9100-1390	1	Inductor: audio	-hp-	
L2	9140-0088	1	Inductor: fxd .33uH +/-5% 200mA	95262	NB 0.37 PS
M1	1120-0909	1	Meter: log calibrated	-hp-	

Table 6-1. Replaceable Parts (Cont'd)

REFERENCE DESIGNATOR	-hp- PART NO.	TQ	DESCRIPTION	MFR.	MFR. PART NO.	
CHASSIS MOUNTED COMPONENTS (Cont'd)						
	03555-67902	1	Power Supply Ass'y	-hp-		
R1	0757-0795	1	R: fxd met flm 75 ohms +/-1% 1/2W	91637	MFF-1/2-T-1	obd
R2	0698-4205	1	R: fxd met flm 21 kilohms +/-1% 1/8W	91637	MF-1/10-32	obd
R3	0698-7371	2	R: fxd met flm 20.605 kilohms +/-0.1% 1/8W	91637	CMF-1/10-32	obd
R4	0698-3158	2	R: fxd met flm 23.7 kilohms +/-1% 1/8W	91637	MF-1/10-32	obd
R5	0698-4488	1	R: fxd met flm 26.7 kilohms +/-1% 1/8W	91637	MF-1/10-32	obd
R6	0698-7371		R: fxd met flm 20.605 kilohms +/-0.1%	91637	CMF-1/10-32	obd
R7	0757-0290	1	R: fxd met flm 6.19 kilohms +/-1% 1/8W	14674	C4	obd
R8	0698-3158		R: fxd met flm 23.7 kilohms +/-1% 1/8W	91637	MF-1/10-32	obd
R9	0698-3245	1	R: fxd flm 20.5 kilohms +/-1% 1/8W	14674	Cr	obd
R10	0757-0455	1	R: fxd met flm 36.5 kilohms +/-1% 1/8W	14674	C4	obd
R11	0698-4434	1	R: fxd met firm 2.32 kilohms +/-1% 1/8W	91637	CMF-1/10-32	obd
S1	3100-1794	1	Switch: lever, input	76854	1332	obd
S2	03555-61904	1	Switch Ass'y: weighting	-hp-		
S3	3101 0045	1	Switch: slide	82389	11A-1014A	
S4,S5	3101 -0001	2	Switch: toggle SPST	04009	80994-HB	
S6	3101-1234	1	Switch: slide DPDT	82389	11A-1242A	
T1	9100-1457	1	Transformer: power	-hp-		
W1	03555-69503	1	Cable Ass'y	-hp-		
W2	03555-69504	1	Cable Ass'y	-hp-		
W3	03555-69502	1	Cable Ass'y	-hp-		
W4	03555-69505	1	Cable Ass'y	-hp-		
W5			Not assigned			
W6	03555-69501	1	Cable Ass'y	-hp-		
W7	03555-61611	1	Cable Ass'y: interconnecting and range	-hp-		
MISCELLANEOUS						
	0340-0099	4	Insulator: binding post	-hp-		
	0340-0100	2	Insulator: binding post single	-hp-		
	0370-0035	1	Knob: bar w/arrow black	-hp-		
	0370-0046	2	Knob: lever switch, black	-hp-		
	0370-0440	8	Knob: pushbuttons, grey	-hp-		
	1390-0137	4	Washer: retaining 1/4 turn fastener	71286	2600-1W	
	1390-0186	4	Stud: 1/4 turn fastener	71286	265424	
	1400-0062	1	Clip: cable	78553	C21891-017-24	
	1400-0076	2	Clip: fuse	75915	101002	
	1520-0001	1	Wafer: cap plate mtg 4 lug	56137	Grade X-831	
	4040-0476	1	Insulator: jack	-hp-		
	5000-7126	1	Decal: pushbutton "75 UNBAL"	-hp-		
	5000-7134	1	Decal: pushbutton "135 BAL"	-hp-		
	5000-7135	1	Decal: pushbutton "150 BAL"	-hp-		
	5000-7136	2	Decal: pushbutton "600 BAL"	-hp-		
	5000-7138	1	Decal: pushbutton "HOLD"	-hp-		
	5000-7139	1	Decal: pushbutton "DIAL-BAT"	-hp-		
	5000-7140	1	Decal: pushbutton "NG"	-hp-		
	5000-7147	1	Decal: pushbutton "900 BAL"	-hp-		
	8120-1518	1	Cord Set: power	70903		obd

Table 6-1. Replaceable Parts (Cont'd)

REFERENCE DESIGNATOR	-hp- PART NO.	TQ	DESCRIPTION	MFR.	MFR. PART NO.
			MISCELLANEOUS (Cont'd)		
	1251-1145	1	Plug: battery	72825	7364
	525C-49A	2	Handle: panel	-hp-	
	00236-04105	1	Cover: battery	-hp-	
	1390-0186		Stud: fastener cadmium plated steel	71286	26542-4
	00741-01212	2	Bracket: meter	-hp-	
	03555-00206	1	Panel: front	-hp-	
	03555-00204	1	Panel: sub	-hp-	
	0340-0732	1	Insul: Bdg Post	-hp-	
	03555-26510	1	Test board: blank	-hp-	
	03555-60604	1	Shield Ass'y: amplifier	-hp-	
	03555-61204	1	Retainer Ass'y: cord/headphone	-hp-	
	0355541203	1	Retainer: headphone	-hp-	
	03556-64507	1	Cover: assembly	-hp-	
	03556-64508	1	Case Assembly	-hp-	
	03556-90007	1	Manual: operating and service	-hp-	

TABLE 6-2.
PART NUMBER - NATIONAL STOCK NUMBER
CROSS REFERENCE INDEX

PART NUMBER	FSCM	NATIONAL STOCK NUMBER	REPLACEMENT		NATIONAL STOCK NUMBER
			PART NUMBER	FSCM	
CB1001	01121	5905-00-989-8653	RCR07G100JS	81349	5905-00-107-0656
CB1041	01121	5905-00-254-7432	RCRO7G104JS	81349	5905-00-110-0388
CB1541	01121	5905-00-726-5345	RCR07G154JS	81349	5905-00-114-5339
CB1805	01121	5905-00-833-0718	RCR07G180JS	81349	5905-00-115-7953
CB2211	01121	5905-00-721-0131	RCR07G221JS	81349	5905-00-135-3973
CB2221	01121	5905-00-726-6433	RCR07G222JS	81349	5905-00-105-7764
CB3921	01121	5905-00-755-0795	RCR07G392JS	81349	5905-00-141-0743
CB4731	01121	5905-00-985-5609	RCR07G473JS	81349	5905-00-141-0717
CB6821	01121	5905-00-721-0671	RCR07G682JS	81349	5905-00-110-7622
CB8211	01121	5905-00-755-0796	RCR07G821JS	81349	5905-00-119-8768
CB8221	01121	5905-00-721-0674	RCR07G822JS	81349	5905-00-104-8358
EAC-301	82389	5935-00-233-6728			
MDL15/100	71400	5920-00-665-3074	F03B250V15-100A	81349	5920-00-661-0530
MPS-3563	04713	5961-00-122-8671			
MT-331	82389	5935-00-201-8993	JJ086	81349	5935-00-192-4826
MT-332-B	82389	5935-00-192-4825			
MT-3428	82389	5935-00-500-7439			
RD5288	07933	5961-00-222-6128	RD5288	49956	5961-00-222-6128
SKA1124	01295	5961-00-137-4608			
SPS3322	04713	5961-00-224-5601			
SPS3611	04713	5961-00-137-0966			
SPS3612	04713	5961-00-137-0967			
SS3651	04713	5961-00-137-0999			
TAS396K015PIC	37942	5910-00-816-2474	M39003-01-2979	81349	5910-00-192-7180
TYPE-GA	78488	5910-00-577-1219	GAO-47PFFORM5PCT	78488	5910-00-834-9437
TYPE-LN821	04713	5961-00-804-7548	JAN1N821	81349	5961-00-866-5454
0698-4521	28480	5905-00-489-2050			
LLA-1014A	82389	5930-00-402-6752			
11A-1242A	82389	5930-00-406-8746			
150D107X0010R2D	56289	5910-00-850-0830			
19C251AL-CDH	56289	5910-00-852-2644			
192P10402-PTS	56289	5910-00-797-9742	192P10452	56289	5910-00-984-2845
2N2904A	04713	5961-00-941-2056			
2600-1W	71286	5325-00-449-3024			
78PCG5	74868	5935-00-919-6391	78PCG5	02660	5935-00-919-6391
80994-HB	04009	5930-00-929-1970			

CODE LIST OF MANUFACTURERS

The following code numbers are from the Federal Supply Code for Manufacturers Cataloging Handbooks H4-1 (Name to Code) and H4-2 (Code to Name) and their latest supplements. The date of revision and the date of the supplements used appear at the bottom of each page. Alphabetical codes have been arbitrarily assigned to suppliers not appearing in the H4 Handbooks.

Code No.	Manufacturer	Address	Code No.	Manufacturer	Address	Code No.	Manufacturer	Address
00000	U. S. A Common	Any supplier of U. S.	05347	Ultronix, Inc.	San Mateo, Cal.	11236	CTS of Berne, Inc.	Berne, Ind.
00136	McCoy Electronics	Mount Holly Springs, Pa.	05397	Union Carbine Corp., Elect.		11237	Chicago Telephone of	
00213	Sage Electronics Corp.	Rochester, N. Y.		Div.	New York, N. Y.		California, Inc.	So. Pasadena, Cal.
00287	Cemco, Inc.	Danielson, Conn.	05574	Viking Ind. Inc.	Canoga Park, Cal.	11242	Bay State Electronics Corp.	Waltham, Mass.
00334	Humidial	Colton, Calif.	05593	Icore Electro-Plastics Inc.	Sunnyvale, Cal.	11312	Teledyne Inc., Microwave	
00348	Mictron, Co., Inc.	Valley Stream, N. Y.	05616	Cosmo Plastic (c/o Electrical			Div.	Palo Alto, Cal.
00373	Garlock Inc.	Cherry Hill, N. J.		Spec. Co.)	Cleveland, Ohio	11314	National Seal	Downey, Cal.
00656	Aerovox Corp.	New Bedford, Mass.	05624	Barber Colman Co.	Rockford, Ill.	11453	Precision Connector Corp.	Jamaica, N. Y.
00779	Amp. Inc.	Harrisburg, Pa.	05728	Tiffen Optical Co.		11534	Duncan Electronics Inc.	Costa Mesa, Cal.
00781	Aircraft Radio Corp.	Boonton, N. J.			Roslyn Heights, Long Island, N. Y.	11711	General Instrument Corp.,	
00809	Croven, Ltd.	Whitby, Ontario, Canada	05729	Metro-Tel Corp.	Westbury, N. Y.		Semiconductor Division Products	
00815	Northern Engineering		05783	Stewart Engineering Co.	Santa Cruz, Cal.		Group	Newark, N. J.
	Laboratories, Inc.	Burlington, Wis.	05820	Wakefield Engineering Inc.	Wakefield, Mass.	11717	Imperial Electronic, Inc.	Buena Park, Cal.
00853	Sangamo Electric Co.,		06004	Bassick Co., Div. of Stewart		11870	Melabs, Inc.	Palo Alto, Cal.
	Pickens Div.	Pickens, S. C.		Warner Corp.	Bridgeport, Conn.	12136	Philadelphia Handle Co.	Camden, N. J.
00866	Goe Engineering Co.	City of Industry, Cal.	06090	Raychem Corp.	Redwood City, Cal.	12361	Grove Mfg. Co., Inc.	Shady Grove, Pa.
00891	Carl E. Holmes Corp.	Los Angeles, Cal.	06175	Bausch and Lomb Optical		12574	Gulton Ind. Inc., Data System	
00929	Microlab Inc.	Livingston, N. J.		Co.	Rochester, N. Y.		Div.	Albuquerque, N. M.
01002	General Electric Co.,		06402	E. T. A. Products Co. of		12697	Clarostat Mfg. Co.	Dover, N. H.
	Capacitor Dept.	Hudson Falls, N. Y.		America	Chicago, Ill.	12728	Elmar Filter Corp.	W. Haven, Conn.
01009	Alden Products Co.	Brockton, Mass.	06540	Amatonic Electronic Hardware		12859	Nippon Electric Co., Ltd.	Tokyo, Japan
01121	Allen Bradley Co.	Milwaukee, Wis.		Co., Inc.	New Rochelle, N. Y.	12881	Metex Electronics Corp.	Clark, N. J.
01255	Litton Industries, Inc.	Beverly Hills, Cal.	06555	Beede Electrical Instrument		12930	Delta Semiconductor Inc.	Newport Beach, Cal.
01281	TRW Semiconductors, Inc.	Lawndale, Cal.		Co., Inc.	Penacook, N. H.	12954	Dickson Electronics Corp.	Scottsdale, Arizona
01295	Texas Instruments, Inc.,		06666	General Devices Co., Inc.	Indianapolis, Ind.	13019	Airco Supply Co., Inc.	Wichita, Kansas
	Transistor Products Div.	Dallas, Texas	06751	Components Inc., Ariz. Div.	Phoenix, Arizona	13061	Wilco Products	Detroit, Mich.
01349	The Alliance Mfg. Co.	Alliance, Ohio	06812	Torrington Mfg. Co., West Div.	Van Nuys, Cal.	13103	Thermolloy	Dallas, Texas
01538	Small Parts Inc.	Los Angeles, Cal.	06980	Varian Assoc. Etmac Div.	San Carlos, Cal.	13327	Solitron Devices Inc.	Tappan, N. Y.
01589	Pacific Relays, Inc.	Van Nuys, Cal.	07088	Kelvin Electric Co.	Van Nuys, Cal.	13396	Telefunken (GmbH)	Hanover, Germany
01670	Gudebrod Bros. Silk Co.	New York, N. Y.	07126	Digitran Co.	Pasadena, Cal.	13835	Midland-Wright Div. of	
01930	Amerock Corp.	Rockford, Ill.	07137	Transistor Electronics			Pacific Industries, Inc.	Kansas City, Kansas
01960	Pulse Engineering Co.	Santa Clara, Cal.		Corp.	Minneapolis, Minn.	14099	Sem-Tech	Newbury Park, Cal.
02114	Ferroxcube Corp. of		07138	Westinghouse Electric		14193	Calif. Resistor Corp.	Santa Monica, Cal.
	America	Saugerties, N. Y.		Corp., Electronic Tube Div.	Elmira, N. Y.	14298	American Components, Inc.	Conshohocken, Pa.
02116	Wheelock Signals, Inc.	Long Branch, N. J.	07149	Filmohm Corp.	New York, N. Y.	14433	ITT Semiconductor, a Div. of	
02286	Cole Rubber and Plastics Inc.	Sunnyvale, Cal.	07233	Cinch-Graphik Co.	City of Industry, Cal.		Int. Telephone and Telegraph	
02660	Amphenol-Borg Electronics		07256	Silicon Transistor Corp.	Carle Place, N. Y.		Corporation	West Palm Beach, Fla.
	Corp.	Broadview, Ill.	07261	Avnet Corp.	Culver City, Cal.	14493	Hewlett-Packard Company	Loveland, Colo.
02735	Radio Corp. of America, Semi-		07263	Fairchild Camera & Inst. Corp.,		14655	Cornell Glass Electric Corp.	Newark, N. J.
	conductor and Materials			Semiconductor Div.	Mountain View, Cal.	14674	Corning Dubler Works	Corning, N. Y.
	Division	Somerville, N. J.	07322	Minnesota Rubber Co.	Minneapolis, Minn.	14752	Electro Cube Inc.	San Gabriel, Cal.
02771	Vocaline Co. of America,		07387	Birtcher Corp, The	Monterey Park, Cal.	14960	Williams Mfg. Co.	San Jose, Cal.
	Inc.	Old Saybrook, Conn.	07397	Sylvania Elect. Prod. Inc.,		15106	The Sphere Co., Inc.	Little Falls, N. J.
02777	Hopkins Engineering Co.	San Fernando, Cal.		Mt. View Operations	Mountain View, Cal.	15203	Webster Electronics Co.	New York, N. Y.
02875	Hudson Tool & Die	Newark, N. J.	07700	Technical Wire Products		15287	Scionics Corp.	Northridge, Cal.
03296	Nylon Molding Corp.	Springfield, N. J.		Inc.	Cranford, N. J.	15291	Adjustable Bushing Co.	N. Hollywood, Cal.
03508	G. E. Semiconductor Prod.		07829	Bodine Elect. Co.	Chicago, Ill.	15558	Micron Electronics	Garden City, Long Island, N. Y.
	Dept.	Syracuse, N. Y.	07910	Continental Device Corp.	Hawthorne, Cal.	15566	Amprobe Inst. Corp.	Lynbrook, N. Y.
03705	Apex Machine & Tool Co.	Dayton, Ohio	07933	Raytheon Mfg. Co., Semi-		15631	Cabletronics	Costa Mesa, Cal.
03797	Eldeama Corp.	Compton, Calif.		conductor Div.	Mountain View, Cal.	15772	Twentieth Century Coil	
03818	Parker Seal Co.	Los Angeles, Cal.	07980	Hewlett-Packard Co.,			Spring Co.	Santa Clara, Cal.
03877	Transitron Electric Corp.	Wakefield, Mass.		New Jersey Division	Rockaway, N. J.	15801	Fenwal Elect. Inc.	Framingham, Mass.
03888	Pyrofilm Resistor Co.,		08145	U. S. Engineering Co.	Los Angeles, Cal.	15818	Amelco Inc.	Mountain View, Cal.
	Inc.	Cedar Knolls, N. J.	08289	Blinn, Delbert Co.	Pomona, Cal.	16037	Spruce Pine Mica Co.	Spruce Pine, N. C.
03954	Singer Co., Diehl Div.,		08358	Burgess Battery Co.		16179	Omni-Spectra Inc.	Detroit, Ill.
	Finderne Plant	Sumerville, N. J.		Niagara Falls, Ontario, Canada		16352	Computer Diode Corp.	Lodi, N. J.
04009	Arrow, Hart and Hegeman		08524	Deutsch Fastener Corp.	Los Angeles, Cal.	16554	Electroid Co.	Union, N. J.
	Elect. Co.	Hartford, Conn.	08664	Bristol Co., The	Waterbury, Conn.	16585	Boots Aircraft Nut Corp.	Pasadena, Cal.
04013	Taruus Corp.	Lambertville, N. J.	08717	Sloan Company	Sun Valley, Cal.	16688	Ideal Prec. Meter Co., Inc.,	
04062	Arco Electronic Inc.	Great Neck, N. Y.	08718	ITT Cannon Electric Inc.,			De Jur Meter Div.	Brooklyn, N. Y.
04217	Essex Wire	Los Angeles, Cal.		Phoenix Div.	Phoenix, Arizona	16758	Delco Radio Div. of G. M. Corp.	Kokomo, Ind.
04222	Hi-Q Division of Aerovox.	Myrtle Beach, S. C.	08727	National Radio Lab. Inc.	Paramus, N. J.	17109	Thermonetics Inc.	Canoga Park, Cal.
04354	Precision Paper Tube Co.	Wheeling, Ill.	08792	CBS Electronics Semiconductor		17474	Tranex Company	Mountain View, Cal.
04404	Palo Alto Division of Hewlett-			Operations, Div. of CBS Inc	Lowell, Mass.	17675	Hamilin Metal Products Corp.	Akron, Ohio
	Packard Co.	Palo Alto, Cal.	08806	General Electric Co.,		17745	Angstrom Prec. Inc.	No. Hollywood, Cal.
04651	Sylvania Electric Products,			Miniature Lamp Dept.	Cleveland, Ohio	17856	Siliconix Inc.	Sunnyvale, Cal.
	Microwave Device Div.	Mountain View, Cal.	08984	Mel-Rain	Indianapolis, Ind.	17870	McGraw-Edison Co.	Manchester, N. H.
04673	Dakota Engr. Inc.	Culver City, Cal.	09026	Babcock Relays Div.	Costa Mesa, Cal.	18042	Power Design Pacific Inc.	Palo Alto, Cal.
04713	Motorola Inc. Semiconductor		09097	Electronic Enclosures Inc.	Los Angeles, Calif.	18083	Clevite Corp. Semiconductor Div.	Palo Alto, Cal.
	Prod. Div.	Phoenix, Arizona	09134	Texas Capacitor Co.	Houston, Texas	18324	Signetics Corp.	Sunnyvale, Cal.
04732	Filttron Co., Inc. Western		09145	Tech. Ind. Inc. Atohm		18476	Ty-Car Mfg. Co., Inc.	Holliston, Mass.
	Div.	Culver City, Cal.		Elect.	Burbank, Cal.	18486	TRW Elect. Comp. Div.	Des Plaines, Ill.
04773	Automatic Electric Co.	Northlake, Ill.	09250	Electro Assemblies, Inc.	Chicago, Ill.	18565	Chomerics	Plainville, Mass.
04796	Sequoia Wire Co.	Redwood City, Cal.	09353	C & K Components Inc.	Newton, Mass.	18583	Curtis Instrument, Inc.	Mt. Kisco, N. Y.
04811	Precision Coil Spring Co.	El Monte, Cal.	09569	Mallory Battery Co. of		18612	Vishay Instruments Inc.	Malvern, Pa.
04870	P. M. Motor Company	Westchester, Ill.		Canada, Ltd.	Toronto, Ontario, Canada	18873	E. I. DuPont and Co., Inc.	Wilmington, Del.
04919	Component Mfg. Service		09795	Pennsylvania Florocarbon	Clifton Heights, Penn.	18911	Durant Mfg. Co.	Milwaukee, Wis.
	Co.	W. Bridgewater, Mass.	09922	Burndy Corp.	Norwalk, Conn.	19315	The Bendix Corp., Navigation &	
05006	Twentieth Century Plastics,		10214	General Transistor Western			Control Div.	Teterboro, N. J.
	Inc.	Los Angeles, Cal.		Corp.	Los Angeles, Cal.	19500	Thomas A. Edison Industries,	
05277	Westinghouse Electric Corp.		10411	Ti-Tal, Inc.	Berkeley, Cal.		Div. of McGraw-Edison	West Orange, N. J.
	Semiconductor Dept.	Youngwood, Pa.	10646	Carborundum Co.	Niagara Falls, N. Y.	19589	Concoa	Baldwin Park, Cal.

00015-49
Revised: May, 1970

From: Handbook Supplements
H4-1 Dated January 1970

CODE LIST OF MANUFACTURERS (Continued)

Code No.	Manufacturer	Address	Code No.	Manufacturer	Address	Code No.	Manufacturer	Address
19644	LRC Electronics	Horseheads, N. Y.	71482	C. P. Clare & Co.	Chicago, Ill.	78452	Thompson-Bremer & Co.	Chicago, Ill.
19701	Electra Mfg. Co.	Independence, Kansas	71590	Centralab Div. of		78471	Tilley Mfg. Co.	San Francisco, Cal.
20183	General Atronics Corp.	Philadelphia, Pa.		Globe Union Inc.	Milwaukee, Wis.	78488	Stackpole Carbon Co.	St. Marys, Pa.
21226	Executone, Inc.	Long Island City, N. Y.	71816	Commercial Plastics Co.	Chicago, Ill.	78493	Standard Thomson Corp.	Waltham, Mass.
21355	Fafnir Bearing Co., The	New Britain, Conn.	71700	Cornish Wire Co., The	New York, N. Y.	78553	Tinnerman Products, Inc.	Cleveland, Ohio
21520	Fansteel Metallurgical Corp.	Chicago, Ill.	71707	Coto Coil Co., Inc.	Providence, R. I.	78790	Transformer Engineers	San Gabriel, Cal.
23020	General Reed Co.	Metuchen, N. J.	71744	Chicago Miniature Lamp Works	Chicago, Ill.	78947	Ucinite Co.	Newtonville, Mass.
23042	Texscan Corp.	Indianapolis, Ind.	71785	Cinch Mfg. Co.,		79136	Waides Kohinoor Inc.	Long Island City, N. Y.
23783	British Radio Electronics Ltd.	Washington, D.C.		Howard B. Jones Div.	Chicago, Ill.	79142	Veeder Root, Inc.	Hartford, Conn.
24455	G. E. Lamp Division, Nela Park	Cleveland, Ohio	71984	Dow Corning Corp.	Midland, Mich.	79251	Wenco Mfg. Co.	Chicago, Ill.
24655	General Radio Co.	West Concord, Mass.	72136	Electro Motive Mfg. Co., Inc.		79272	Continental-Wirt Electronics Corp.	Philadelphia, Pa.
24681	Memcor Inc., Comp. Div.	Huntington, Ind.			Willimantic, Conn.			
26365	Gries Reproducer Corp.	New Rochelle, N. Y.	72619	Dialight Corp.	Brooklyn, N. Y.	79963	Zierick Mfg. Corp.	New Rochelle, N. Y.
26462	Grobert File Co. of America, Inc.	Carlstadt, N. J.	72656	Indiana General Corp.,		80031	Mepco Division of Sessions Clock Co.	
26851	Compac/Hollister Co.	Hollister, Cal.		Electronics Div.	Keasby, N. J.			
26992	Hamilton Watch Co.	Lancaster, Pa.	72699	General Instrument Corp.,		80033	Prestole Corp.	Toledo, Ohio
28480	Hewlett-Packard Co.	Palo Alto, Cal.		Cap Division	Newark, N. J.	80120	Schnitzer Alloy Products Co.	Elizabeth, N. J.
28520	Heyman Mfg. Co.	Kenilworth, N. J.	72765	Drake Mfg. Co.	Harwood Heights, Ill.	80131	Electronic Industries Association.	
30817	Instrument Specialties Co.,		72825	Hugh H. Eby Inc.	Philadelphia, Pa.		Standard tube or semi-conductor device,	
	Inc.	Little Falls, N. J.	72928	Gudeman Co.	Chicago, Ill.		any manufacturer.	
33173	G. E. Receiving Tube Dept.	Owensboro, Ky.	72962	Elastic Stop Nut Corp.	Union, N. J.	80207	Unimax Switch, Div. Maxon Electronics	
35434	Lectrohm Inc.	Chicago, Ill.	72964	Robert M. Hadley Co.	Los Angeles, Cal.		Corp.	Wallingford, Conn.
36196	Stanwyck Coil Products		72982	Erie Technological Products, Inc.	Erie, Pa.	80223	United Transformer Corp.	New York, N. Y.
	Ltd.	Hawkesbury, Ontario, Canada	73061	Hansen Mfg. Co., Inc.	Princeton, Ind.	80248	Oxford Electric Corp.	Chicago, Ill.
36287	Cunningham, W. H. & Hill,		73076	H. M. Harper Co.	Chicago, Ill.	80294	Bourns Inc.	Riverside, Cal.
	Ltd.	Toronto, Ontario, Canada	73138	Helipot Div. of Beckman Inst., Inc.		80411	Arco Div. of Robertshaw Controls Co.	
37942	P. R. Mallory & Co., Inc.	Indianapolis, Ind.			Fullerton, Cal.			
39543	Mechanical Industries Prod. Co.	Akron, Ohio	73293	Hughes Products Division of		80486	All Star Products Inc.	Columbus, Ohio
40920	Miniature Precision Bearings, Inc.	Keene, N. H.		Hughes Aircraft Co.	Newport Beach, Cal.	80509	Avery Label Co.	Monrovia, Cal.
40931	Honeywell Inc.	Minneapolis, Minn.	73445	Amperex Elect. Co.	Hicksville, L. I., N. Y.	80583	Hammarlund Co., Inc.	Mars Hill, N. C.
42190	Muter Co.	Chicago, Ill.	73506	Bradley Semiconductor Corp.		80640	Stevens, Arnold, Co., Inc.	Boston, Mass.
43990	C. A. Norgren Co.	Englewood, Colo.			New Haven, Conn.	80813	Dimco Gray Co.	Dayton, Ohio
44655	Ohmite Mfg. Co.	Skokie, Ill.	73559	Carling Electric, Inc.	Hartford, Conn.	81030	International Inst. Inc.	Orange, Conn.
46384	Penn Eng. & Mfg. Corp.	Doylstown, Pa.	73586	Circle F Mfg. Co.	Trenton, N. J.	81073	Grayhill Co.	LaGrange, Ill.
47904	Polaroid Corp.	Cambridge, Mass.	73682	George K. Garrett Co.		81095	Triad Transformer Corp.	Venice, Cal.
48620	Precision Thermometer &			Div. MSL Industries, Inc.	Philadelphia, Pa.	81312	Winchester Elec. Div. Litton Ind., Inc.	
	Inst. Co.	Southampton, Pa.	73734	Federal Screw Products, Inc.	Chicago, Ill.			Oakville, Conn.
49956	Microwave & Power Tube Div.	Waltham, Mass.	73743	Fischer Special Mfg. Co.	Cincinnati, Ohio	81349	Military Specification	
52090	Rowan Controller Co.	Westminster, Md.	73793	General Industries Co., The	Elyria, Ohio	81483	International Rectifier Corp.	El Segundo, Cal.
52983	HP Co., Med. Elec. Div.	Waltham, Mass.	73846	Goshen Stamping & Tool Co.	Goshen, Ind.	81541	Airpac Electronics, Inc.	Cambridge, Maryland
54294	Shallcross Mfg. Co.	Selma, N. C.	73899	JFD Electronics Corp.	Brooklyn, N. Y.	81860	Barry Controls, Div. Barry Wright Corp.	
55026	Simpson Electric Co.	Chicago, Ill.	73905	Jennings Radio Mfg. Corp.	San Jose, Cal.			Watertown, Mass.
55933	Sonotone Corp.	Elmsford, N. Y.	73957	Groove-Pin Corp.	Ridgefield, N. J.	82042	Carter Precision Electric Co.	Skokie, Ill.
55938	Raytheon Co. Commercial Apparatus		74276	Signalite Inc.	Neptune, N. J.	82047	Sperti Faraday Inc., Copper Hewitt	
	& System Div.	So. Norwalk, Conn.	74455	J. H. Winns, and Sons	Winchester, Mass.		Electric Div.	Hoboken, N. J.
56137	Spaulding Fibre Co., Inc.	Tonawanda, N. Y.	74861	Industrial Condenser Corp.	Chicago, Ill.	82116	Electric Regulator Corp.	Norwalk, Conn.
56289	Sprague Electric Co.	North Adams, Mass.	74868	R. F. Products Division of		82142	Jeffers Electronics Division of	
58474	Superior Elect. Co.	Bristol, Conn.		Amphenol-Borg Electronic Corp.			Speer Carbon Co.	Du Bois, Pa.
59446	Telex Corp.	Tulsa, Okla.	74970	E. F. Johnson Co.	Danbury, Conn.	82170	Fairchild Camera & Inst. Corp.,	
59730	Thomas & Betts Co.	Elizabeth, N. J.	75042	International Resistance Co.	Philadelphia, Pa.		Space & Defense Systems Div.	Paramus, N. J.
60741	Triplett Electrical Inst. Co.	Bluffton, Ohio	75263	Keystone Carbon Co., Inc.	St. Marys, Pa.	82209	Magurie Industries, Inc.	Greenwich, Conn.
61775	Union Switch and Signal Div. of		75378	KTS Knights, Inc.	Sandwich, Ill.	82219	Sylvania Electric Prod., Inc.	
	Westinghouse Air Brake Co.	Pittsburgh, Pa.	75382	Culka Electric Corp.	Mt. Vernon, N. Y.		Electronic Tube Division	Emporium, Pa.
62119	Universal Electric Co.	Owosso, Mich.	75818	Lenz Electric Mfg. Co.	Chicago, Ill.	82376	Astron Corp.	East Newark, Harrison, N. J.
63743	Ward-Leonard Electric Co.	Mt. Vernon, N. Y.	75915	Littlefuse, Inc.	Des Plaines, Ill.	82389	Switchcraft, Inc.	Chicago, Ill.
64959	Western Electric Co., Inc.	New York, N. Y.	76005	Lord Mfg. Co.	Erie, Pa.	82647	Metals & Controls Inc.,	
65092	Weston Inst. Inc. Weston-Newark	Newark, N. J.	76210	C. W. Marwedel	San Francisco, Cal.		Spencer Products	Attleboro, Mass.
66295	Wittek Mfg. Co.	Chicago, Ill.	76433	General Instrument Corp.,		82768	Phillips-Advance Control Co.	Joliet, Ill.
66346	Minnesota Mining & Mfg. Co.			Micamold Division	Newark, N. J.	82866	Research Products Corp.	Madison, Wis.
	Revere Mincow Div.	St. Paul, Minn.	76487	James Millen Mfg. Co., Inc.	Malden, Mass.	82877	Rolton Mfg. Co., Inc.	Woodstock, N. Y.
70276	Allen Mfg. Co.	Hartford, Conn.	76493	J. H. Miller Co.	Los Angeles, Cal.	82893	Vector Electronic Co.	Glendale, Cal.
70309	Allied Control	New York, N. Y.	76530	Cinch-Monadnock, Div. of United Carr		83058	Carr Fastener Co.	Cambridge, Mass.
70318	Allmetal Screw Product Co., Inc.			Fastener Corp.	San Leandro, Cal.	83086	New Hampshire Ball	
		Garden City, N. Y.			Cleveland, Ohio		Bearing, Inc.	Peterborough, N. H.
70417	Amplex, Div. of Chrysler Corp.	Detroit, Mich.	76545	Mueller Electric Co.	Cleveland, Ohio	83125	General Instrument Corp.,	
70485	Atlantic India Rubber Works, Inc.	Chicago, Ill.	76703	National Union	Newark, N. J.		Capacitor Div.	Darlington, S. C.
70563	Amperite Co., Inc.	Union City, N. J.	76854	Oak Manufacturing Co.	Crystal Lake, Ill.	83148	ITT Wire and Cable Div.	Los Angeles, Cal.
70674	ADC Products Inc.	Minneapolis, Minn.	77068	The Bendix Corp.,		83186	Victory Eng. Corp.	Springfield, N. J.
70903	Belden Mfg. Co.	Chicago, Ill.		Electrodynamics Div.	N. Hollywood, Cal.	83298	Bendix Corp., Red Bank Div.	Red Bank, N. J.
70998	Bird Electric Corp.	Cleveland, Ohio	77075	Pacific Metals Co.	San Francisco, Cal.	83315	Hubbell Corp.	Mundelein, Ill.
71002	Birnbach Radio Co.	New York, N. Y.	77221	Phaostroan Instrument and		83324	Rossan Inc.	Newport Beach, Cal.
71034	Bliley Electric Co., Inc.	Erie, Pa.		Electronic Co.	So. Pasadena, Cal.	83330	Smith, Herman H., Inc.	Brooklyn, N. Y.
71041	Boston Gear Works Div. of		77252	Philadelphia Steel and		83332	Tech Labs	Palisades Park, N. J.
	Murray Co. of Texas	Quincey, Mass.		Wire Corp.	Philadelphia, Pa.	83385	Central Screw Co.	Chicago, Ill.
71218	Bud Radio, Inc.	Willoughby, Ohio	77342	American Machine & Foundry Co.		83501	Gavitt Wire and Cable Co., Div. of	
71279	Cambridge Thermionics Corp.	Cambridge, Mass.		Potter & Brumfield Div.	Princeton, Ind.		Amerace Corp.	Brookfield, Mass.
71286	Camloc Fastener Corp.	Paramus, N. J.	77630	TRW Electronic Components Div.	Camden, N. J.	83594	Burroughs Corp., Electronic	
71313	Cardwell Condenser Corp.		77638	General Instrument Corp.,			Tube Div.	Plainfield, N. J.
		Lindenhurst, L. I., N. Y.		Rectifier Division	Brooklyn, N. Y.	83740	Union Carbide Corp., Consumer	
71400	Bussmann Mfg. Div. of		77764	Resistance Products Co.	Harrisburg, Pa.		Prod. Div.	New York, N. Y.
	McGraw-Edison Co.	St. Louis, Mo.	77969	Rubbercraft Corp. of Calif.	Torrance, Cal.	83777	Model Eng. and Mfg., Inc.	Huntington, Ind.
71436	Chicago Condenser Corp.	Chicago, Ill.	78189	Shakeproof Division of		83821	Loyd Scruggs Co.	Festus, Mo.
71447	Calif. Spring Co., Inc.	Pico-Rivera, Cal.		Illinois Tool Works	Elgin, Ill.	83942	Aeronautical Inst. & Radio Co.	Lodi, N. J.
71450	CTS Corp.	Elkhart, Ind.	78277	Sigma	So. Braintree, Mass.	84171	Arco Electronics Inc.	Great Neck, N. Y.
71468	ITT Cannon Electric Inc.	Los Angeles, Cal.	78283	Signal Indicator Corp.	New York, N. Y.	84396	A. J. Glesener Co., Inc.	San Francisco, Cal.
71471	Cinema, Div. Aerovox Corp.	Burbank, Cal.	78290	Struthers-Dunn Inc.	Pitman, N. J.	84411	TRW Capacitor Div.	Ogallala, Neb.

CODE LIST OF MANUFACTURERS (Continued)

CODE LIST OF MANUFACTURERS (Continued)

Code No.	Manufacturer	Address	Code No.	Manufacturer	Address	Code No.	Manufacturer	Address
84870	Sarkes Tarzian, Inc.	Bloomington, Ind.	91929	Honeywell Inc., Micro Switch Division	Freeport, Ill.	96095	Hi-Q Div. of Aerovox Corp.	Olean, N. Y.
85454	Boonton Molding Company	Boonton, N. J.			Oakland, Cal.	96256	Thordarson-Meissner Inc.	Mt. Carmel, Ill.
85471	A. B. Boyd Co.	San Francisco, Cal.	91961	Nahn-Bros. Spring Co.	Peabody, Mass.	96296	Solar Mfg. Co.	Los Angeles, Cal.
85474	R. M. Bracamonte & Co.	San Francisco, Cal.	92180	Tru-Connector Corp.	Rochester, N. Y.	96396	Microswitch, Div. of	Freeport, Ill.
85660	Kolled Kords, Inc.	Hamden, Conn.	92367	Elgeet Optical Co., Inc.	Tarrytown, N. Y.		Minn.-Honeywell	Chicago, Ill.
85911	Seamless Rubber Co.	Chicago, Ill.	92607	Tensolite Insulated Wire Co., Inc.	Westbury, L. I., N. Y.	96330	Carlton Screw Co.	Burlington, Mass.
86174	Fafnir Bearing Co.	Los Angeles, Calif.			Kearney, N. J.	96341	Microwave Associates, Inc.	Oakland, Cal.
86197	Clifton Precision Products Co., Inc.	Clifton Heights, Pa.	92702	IMC Magnetics Corp.	Woburn, Mass.	96501	Excel Transformer Co.	Orchard Park, N. Y.
		Dayton, Ohio	92966	Hudson Lamp Co.	Pallisades Park, N. J.	96508	Xcelite, Inc.	San Fernando, Cal.
86579	Precision Rubber Products Corp.	Harrison, N. J.	93332	Sylvania Electric Prod. Inc., Semiconductor Div.	Essex, Mass.	96733	San Fernando Elec. Mfg. Co.	Long Island, N. Y.
86684	Radio Corp. of America, Electronic Comp. & Devices Division	Glendale, Cal.	93369	Robbins & Myers Inc.	Livingston, N. J.	96881	Thomson Ind. Inc.	Irvington, N. J.
86928	Seastrom Mfg. Co.	Anaheim, Cal.	93410	Stemco Controls, Div. of Essex Wire Corp.	Culver City, Cal.	97464	Industrial Retaining Ring Co.	Englewood, N. J.
87034	Marco Industries	Lansdale, Pa.	93632	Waters Mfg. Co.	Bayonne, N. J.	97539	Automatic & Precision Mfg.	Yonkers, N. Y.
87216	Philco Corporation (Lansdale Division)	San Francisco, Cal.	93929	G. V. Controls	Quincy, Mass.	97979	Reon Resistor Corp.	Adler-Westrex Commun. Div.
87473	Western Fibrous Glass Products Co.	Providence, R. I.	94137	General Cable Corp.	Loveland, Colo.	97983	Litton System Inc.,	New Rochelle, N. Y.
		Lincoln, Ill.	94144	Raytheon Co., Comp. Div., Ind. Comp. Operations	Newark, N. J.	98141	R-Tronics, Inc.	Jamaica, N. Y.
87664	Van Waters & Rogers Inc.	St. Paul, Minn.	94148	Scientific Electronics Products, Inc.	East Patterson, N. J.	98159	Rubber Teck, Inc.	Gardena, Cal.
87930	Tower Mfg. Corp.	Buffalo, N. Y.	94154	Wagner Elect. Corp., Tung-Sol Div.	East Chester, Pa.	98220	Hewlett-Packard Co., Medical Elec. Div.	Pasadena, Cal.
88140	Cutler-Hammer, Inc.	Oakland, Cal.	94197	Curtiss-Wright Corp., Electronics Div.	Bellwood, Ill.	98278	Microdot, Inc.	So. Pasadena, Cal.
88220	Gould-National Batteries, Inc.	Schenectady, N. Y.	94222	South Chester Corp.	Brooklyn, N. Y.	98291	Sealectro Corp.	Mamaroneck, N. Y.
88698	General Mills, Inc.	Detroit, Mich.	94330	Wire Cloth Products, Inc.	Worcester, Mass.	98376	Zero Mfg. Co.	Burbank, Cal.
89231	Graybar Electric Co.	Chicago, Ill.	94375	Automatic Metal Products Co.	Worcester, Mass.	98410	Etc. Inc.	Cleveland, Ohio
89473	G. E. Distributing Corp.	Chicago, Ill.	94682	Worcester Pressed Aluminum Corp.	Chicago, Ill.	98731	General Mills Inc., Electronics Div.	Minneapolis, Minn.
89479	Security Co.	Beverly, Mass.	94696	Magnecraft Electric Co.	Chicago, Ill.	98734	Paeco Division of Hewlett-Packard Co.	Palo Alto, Cal.
89665	United Transformer Co.	Passaic, N. J.	95023	George A. Philbrick Researchers, Inc.	Boston, Mass.	98821	North Hills Electronics, Inc.	Glen Cove, N. Y.
90030	United Shoe Machinery Corp.	Belleville, Ill.	95146	Alco Elect. Mfg. Co.	Lawrence, Mass.	98978	International Electronic Research Corp.	Burbank, Cal.
90179	U. S. Rubber Co., Consumer Ind. & Plastics Prod. Div.	Chicago, Ill.	95236	Allies Products Corp.	Diania, Fla.	99109	Columbia Technical Corp.	New York, N. Y.
90365	Belleville Speciality Tool Mfg., Inc.	San Francisco, Cal.	95238	Continental Connector Corp.	Woodside, N. Y.	99313	Varian Associates	Palo Alto, Cal.
90763	United Carr Fastener Corp.	San Francisco, Cal.	95263	Leecraft Mfg. Co., Inc.	Long Island, N. Y.	99378	Atlee Corp.	Winchester, Mass.
90970	Bearing Engineering Co.	El Monte, Cal.	95265	National Coil Co.	Sheridan, Wyo.	99515	Marshall Ind., Capacitor Div.	Monrovia, Cal.
91146	ITT Cannon Elect. Inc., Salem Div.	Chicago, Ill.	95275	Vitramon, Inc.	Bridgeport, Conn.	99707	Control Switch Division, Controls Co. of America	El Segundo, Cal.
		Salem, Mass.	95348	Gordos Corp.	Bloomfield, N. J.	99800	Delevan Electronics Corp.	East Aurora, N. Y.
91260	Connor Spring Mfg. Co.	Chicago, Ill.	95354	Method Mfg. Co.	Rolling Meadows, Ill.	99848	Wilco Corporation	Indianapolis, Ind.
91345	Miller Dial & Nameplate Co.	Chicago, Ill.	95566	Arnold Engineering Co.	Marengo, Ill.	99928	Branson Corp.	Whippany, N. J.
91418	Radio Materials Co.	Chicago, Ill.	95712	Dage Electric Co., Inc.	Franklin, Ind.	99934	Rembrandt, Inc.	Boston, Mass.
91506	Augat Inc.	Chicago, Ill.	95984	Stemon Mfg. Co.	Wayne, Ill.	99942	Hoffman Electronics Corp., Semiconductor Division	El Monte, Cal.
91637	Dale Electronics, Inc.	Chicago, Ill.	95987	Weckesser Co.	Chicago, Ill.	99957	Technology-Instrument Corp.	California
91662	Elco Corp.	Chicago, Ill.	96087	Microwave Assoc., West, Inc.	Sunnyvale, Cal.			Newbury Park, Cal.
91673	Ephphone Inc.	Chicago, Ill.						
91737	Gremar Mfg. Co., Inc.	Chicago, Ill.						
91827	K F Development Co.	Chicago, Ill.						
91886	Malco Mfg., Inc.	Chicago, Ill.						

The following HP Vendors have no number assigned in the latest supplement to the Federal Supply Code for Manufacturers Handbook.

0000F	Malco Tool and Die	Los Angeles, Calif.	000CS	Hewlett-Packard Co., Colorado Springs Div.	Colorado Springs, Colorado	000QQ	Cooltron	Oakland, Cal.
0000Z	Willow Leather Products Corp.	Newark, N. J.	000MM	Rubber Eng. & Development	Hayward, Cal.	000WW	California Eastern Lab.	Burlington, Cal.
000AB	ETA	England	000NN	A "N" D Mfg. Co.	San Jose, Cal.	000YY	S. K. Smith Co.	Los Angeles, Cal.
000BB	Precision Instrument Comp. Co.	Van Nuys, Cal.						

SUPPLEMENTAL CODE LIST OF MANUFACTURERS

Code No.	Manufacturer	Address
12040	National Semiconductor Corp.	Danbury, Conn.

**SECTION VII
CIRCUIT DIAGRAMS**

7-1. INTRODUCTION.

7-2. This section of the Manual contains circuit diagrams for the Model 3555B Transmission and Noise Measuring Set. The functional block diagram (Figure 7-1) contains signal levels to assist in troubleshooting. The schematic diagrams (Figures 7-2 through 7-5) show dc voltage levels which should also aid in locating faulty components.

7-3. FUNCTIONAL BLOCK DIAGRAM.

7-4. The functional block diagram (Figure 7-1) of the 3555B serves the dual purpose of showing how various circuits are arranged to form the set and at the same time gives voltages and adjustments for use in troubleshooting the set. This functional block diagram

should be used in conjunction with the troubleshooting procedure described in Section V.

7-5. SCHEMATIC DIAGRAMS.

7-6. The schematic diagrams (Figures 7-2 through 7-5) contained in this section show the detailed circuits in the Model 3555B. Components marked with an asterisk are those that are critical in value. The value of these components may vary slightly from one set to another due to variations in transistor Beta etc, and the values shown on the schematic are average.

7-7. Voltage levels have been included on the schematics which should greatly assist in troubleshooting the set. When measuring these voltages a high input impedance voltmeter (1 megohm or greater) should be used to prevent circuit loading.

REFERENCE DESIGNATIONS

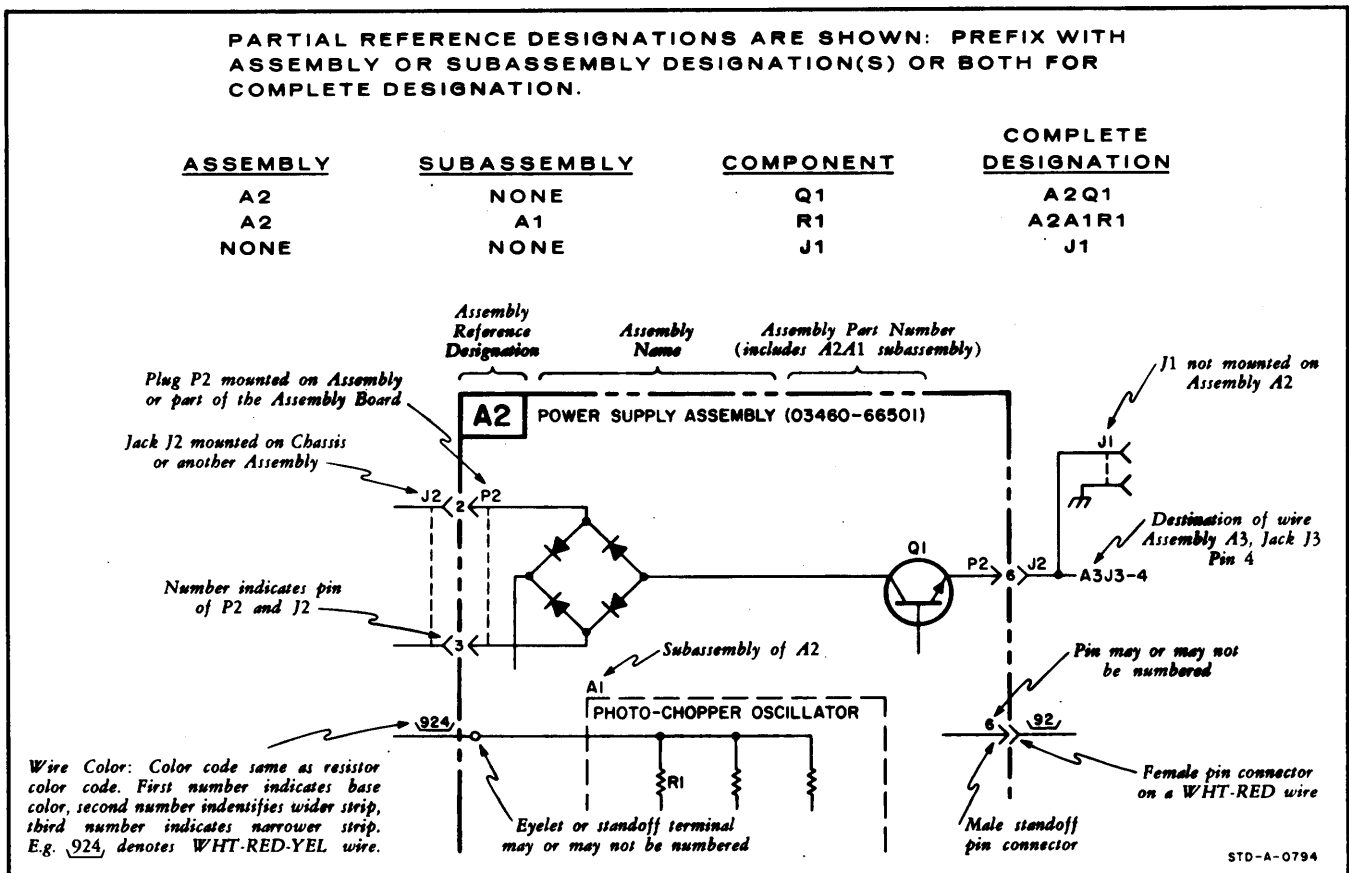









SCHEMATIC NOTES

1. PARTIAL REFERENCE DESIGNATIONS ARE SHOWN. PREFIX WITH ASSEMBLY OR SUBASSEMBLY DESIGNATION(S) OR BOTH FOR COMPLETE DESIGNATION.
2. COMPONENT VALUES ARE SHOWN AS FOLLOWS UNLESS OTHERWISE NOTED.

RESISTANCE IN OHMS

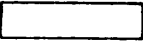
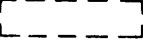
CAPACITANCE IN MICROFARADS

3.  DENOTES ASSEMBLY CIRCUIT GROUND.
4.  DENOTES CHASSIS CIRCUIT GROUND.
5.  DENOTES POWER LINE GROUND.
6.  DENOTES ASSEMBLY.
7.  DENOTES MAIN SIGNAL PATH.
8.  DENOTES FEEDBACK PATH.
9.  DENOTES FRONT PANEL MARKING.
10.  DENOTES SIDE AND REAR PANEL MARKING.
11.  DENOTES SCREWDRIVER ADJUST.
12. 924 DENOTES WIRE COLOR: COLOR CODE SAME AS RESISTOR COLOR CODE. FIRST NUMBER IDENTIFIES BASE COLOR, SECOND NUMBER IDENTIFIES WIDER STRIP, THIRD NUMBER IDENTIFIES NARROWER STRIP.
(e. g. 924, = WHITE, RED, YELLOW.)
13. * AVERAGE VALUE SHOWN, OPTIMUM VALUE SELECTED AT FACTORY.
14. TRANSISTORS ARE ALL CONNECTED TO CIRCUIT BOARD IN TO-5 CONFIGURATION, ie,  AS VIEWED FROM THE COMPONENT SIDE OF BOARD.
15. WAVEFORM AND VOLTAGE MEASUREMENTS WERE MADE WITH RESPECT TO CHASSIS GROUND USING A HIGH INPUT IMPEDANCE (GREATER THAN 1 MEGOHM) OSCILLOSCOPE AND TRANSISTOR VOLTMETER. VOLTAGE LEVELS SHOWN ARE NOMINAL AND MAY VARY SOMEWHAT FROM ONE INSTRUMENT TO ANOTHER. A VARIATION OF +/-10% IN MEASUREMENTS SHOULD BE ALLOWED.

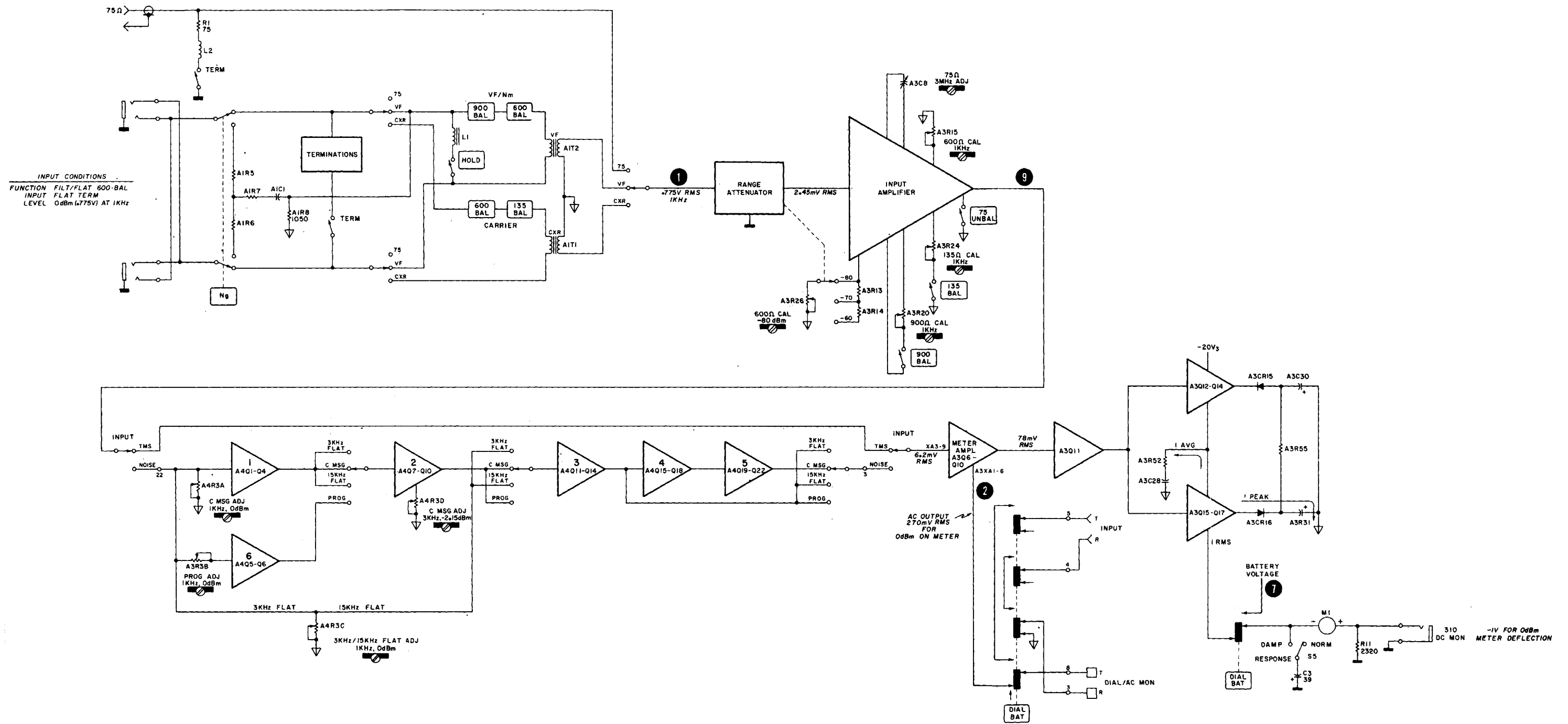

Figure 7-1. Functional Block Diagram

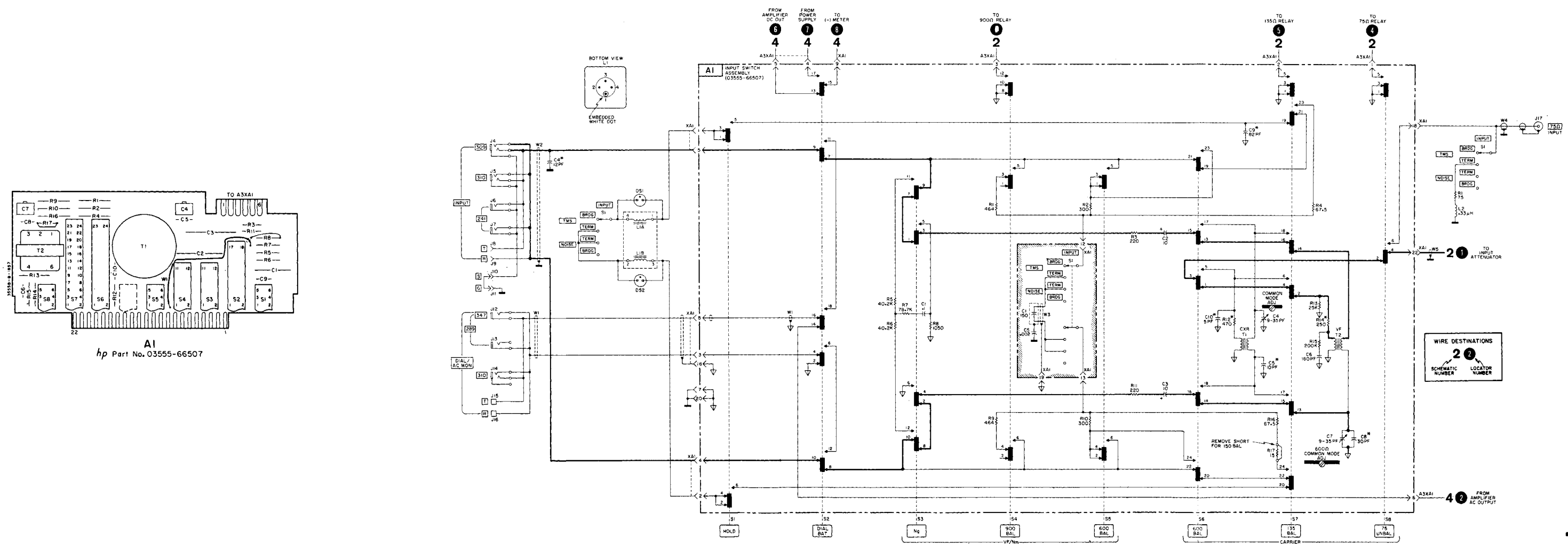
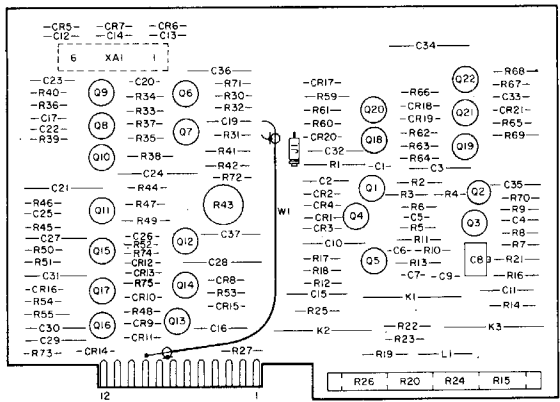
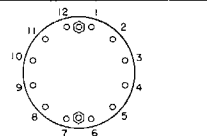
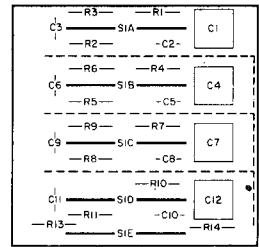

Figure 7-2. A1 Function Assembly Schematic and Component Location

7-5/7-6

A2
hp Part No. 03555-66509



A3
hp Part No. 03555-66508

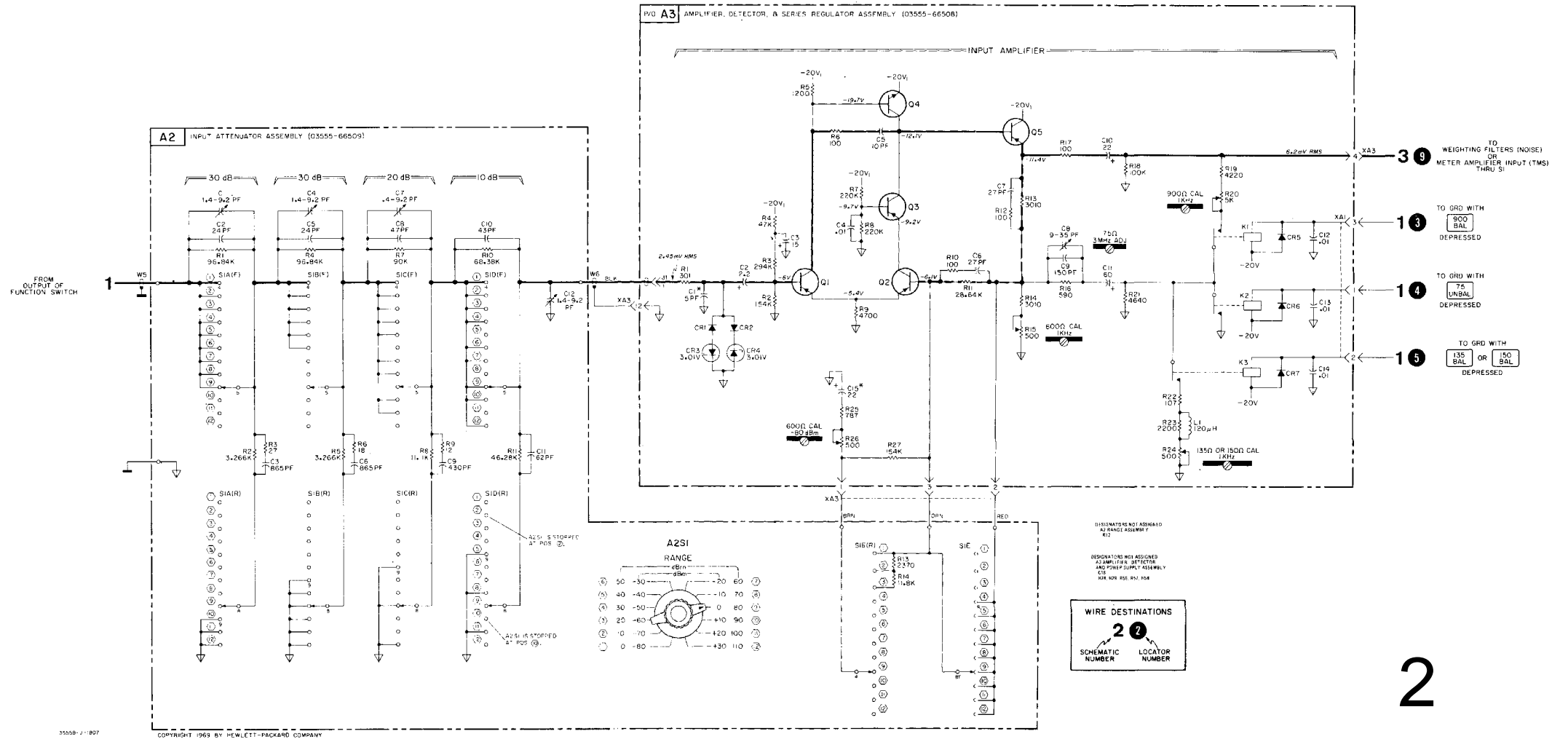
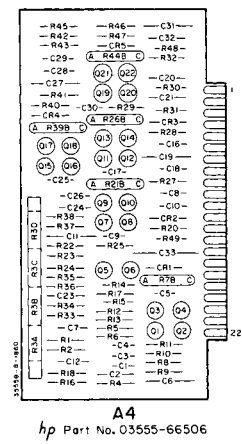

Figure 7-3. A2 Range Attenuator and A3 Input Amplifier Schematic and Component Location



A4
hp Part No. 03555-66506

NOTE

1. Refer to Appendix C, change no. 3 for backdating.

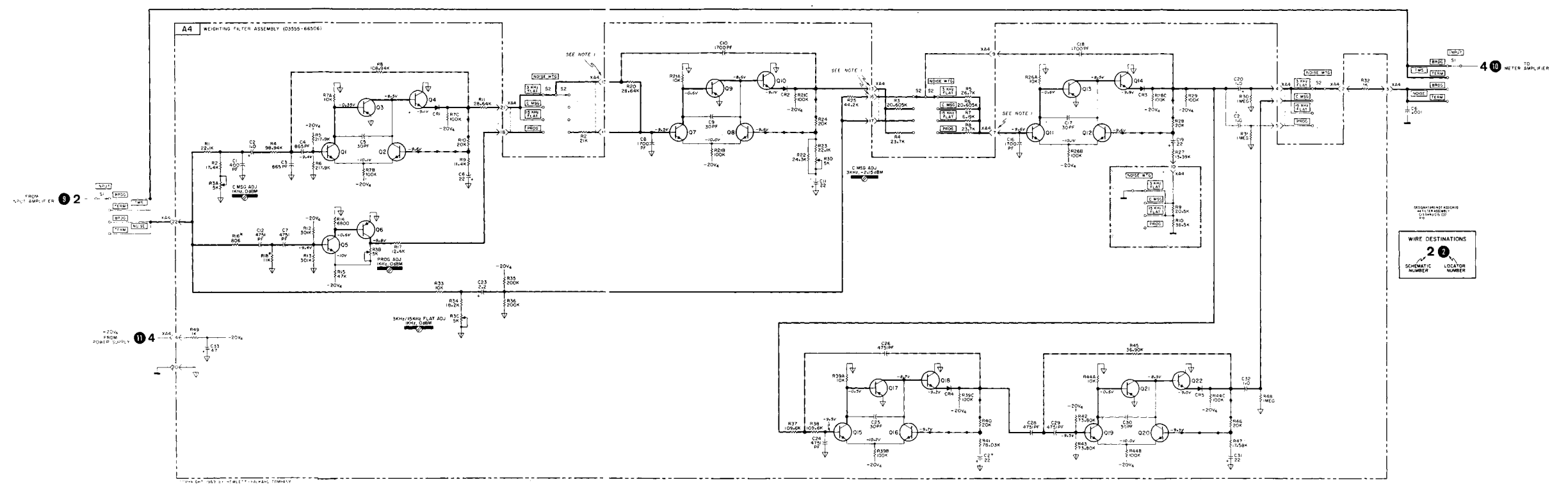

Figure 7-4. A4 Filter Schematic and Component Location

7-9/7-10

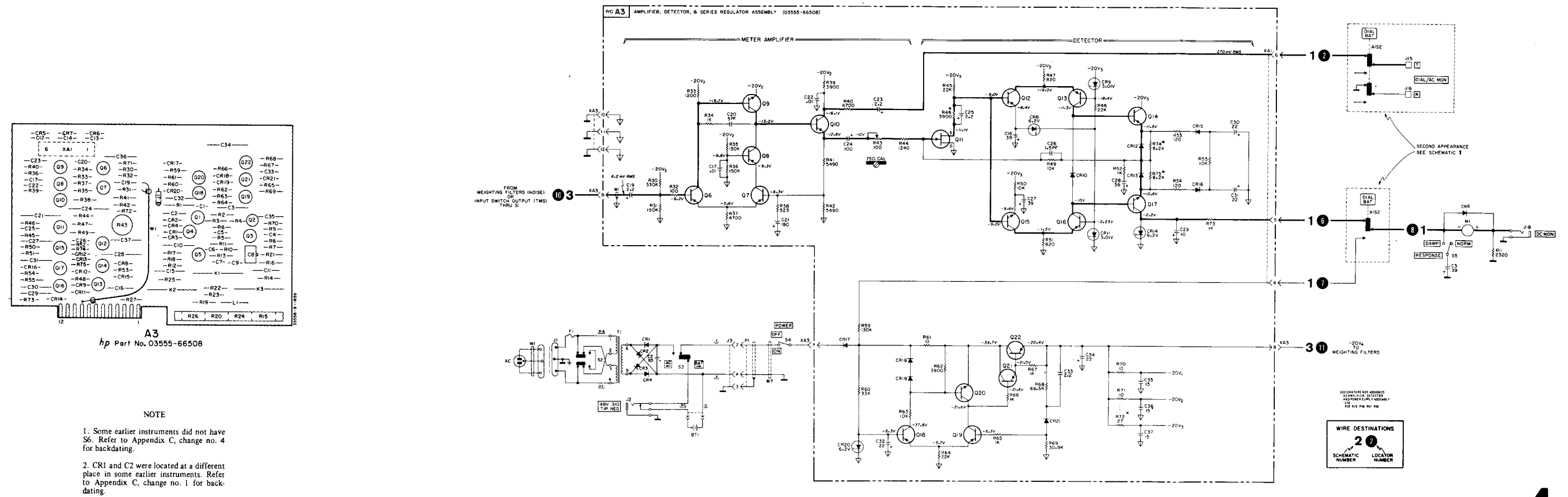

Figure 7-5. A3 Meter Amplifier, Detector and Series Regulator Schematic and Component Locations

7-11/7-12

APPENDIX A REFERENCES

DA Pam 310-4	Index of Technical Manuals, Technical Bulletins, Supply Manuals (Types 7, 8, and 9), Supply Bulletins and Lubrication Orders.
DA Pam 310-7	US Army Equipment Index of Modification Work Orders.
TM 11-6625-320-12	Operator's and Organizational Maintenance Manual: Voltmeters ME-30A/U, and voltmeters, Electronic, ME-30B/U, ME-30C/U and ME30E/U.
TM 11-6625-683-15	Operator's Organizational, Direct Support, General Support and Depot Maintenance Manual: Signal Generator AN/URM-127 (NSN 6625-00-783-5965).
TM 11-6625-2953-14	Operator's, Organizational, Direct Support, and General Support Maintenance Manual: Multimeter AN/USM-451 (NSN 6625-01-060-6804).
TM 38-750	The Army Maintenance Management System (TAMMS).
TM 740-90-1	Administrative Storage of Equipment.
TM 750-244-2	Procedures for Destruction of Electronics Materiel to Prevent Enemy Use (Electronics Command).

APPENDIX B
MAINTENANCE ALLOCATION
Section I. INTRODUCTION

B-1. General

This appendix provides a summary of the maintenance operations for TA-885/U. It authorizes categories of maintenance for specific maintenance functions on repairable items and components and the tools and equipment required to perform each function. This appendix may be used as an aid in planning maintenance operations.

B-2. Maintenance Function

Maintenance function will be limited to and defined as follows:

a. Inspect. To determine the serviceability of an item by comparing its physical, mechanical, and/or electrical characteristics with established standards through examination.

b. Test. To verify serviceability and to detect incipient failure by measuring the mechanical or electrical characteristics of an item and comparing those characteristics with prescribed standards.

c. Service. Operations required periodically to keep an item in proper operating condition, i.e., to clean (decontaminate), to preserve, to drain, to paint, or to replenish fuel, lubricants, hydraulic fluids, or compressed air supplies.

d. Adjust. To maintain, within prescribed limits, by bringing into proper or exact position, or by setting the operating characteristics to the specified parameters.

e. Align. To adjust specified variable elements of an item to bring about optimum or desired performance.

f. Calibrate. To determine and cause corrections to be made or to be adjusted on instruments or test measuring and diagnostic equipments used in precision measurement. Consists of comparisons of two instruments, one of which is a certified standard of known accuracy, to detect and adjust any discrepancy in the accuracy of the instrument being compared.

g. Install. The act of emplacing, seating, or fixing into position an item, part, module (component or assembly) in a manner to allow the proper functioning of the equipment or system.

h. Replace. The act of substituting a serviceable like type part, subassembly, or module (component or assembly) for an unserviceable counterpart.

i. Repair. The application of maintenance services (inspect, test, service, adjust, align, calibrate, replace) or other maintenance actions (welding, grinding, riveting, straightening, facing, remachining, or resurfacing) to restore serviceability to an item by correcting specific, damage, fault, malfunction, or failure in a part, subassembly, module (component or assembly), end item, or system.

j. Overhaul. That maintenance effort (service/action) necessary to restore an item to a completely serviceable/operational condition as prescribed by maintenance standards (i.e., DMWR) in appropriate technical publications. Overhaul is normally the highest degree of maintenance performed by the Army. Overhaul does not normally return an item to like new condition.

k. Rebuild. Consists of those services/actions necessary for the restoration of serviceable equipment to a like new condition in accordance with original manufacturing standards. Rebuild is the highest degree of materiel maintenance applied to Army equipment. The rebuild operation includes the act of returning to zero those age measurements (hours, miles, etc.) considered in classifying Army equipments/components.

B-3. Column Entries

a. Column 1, Group Number. Column 1 lists group numbers, the purpose of which is to identify components, assemblies, subassemblies, and modules with the next higher assembly.

b. Column 2, Component/Assembly. Column 2 contains the noun names of components, assemblies, subassemblies, and modules for which maintenance is authorized.

c. Column 3, Maintenance Functions. Column 3 lists the functions to be performed on the item listed in column 2. When items are listed without maintenance functions, it is solely for purpose of having the group numbers in the MAC and RPSTL coincide.

d. Column 4, Maintenance Category. Column 4 specifies, by the listing of a "work time" figure in the appropriate subcolumn(s), the lowest level of maintenance authorized to perform the function listed in column 3. This figure represents the active time required to perform that maintenance function at the indicated category of maintenance. If the number or complexity of the tasks within the listed maintenance function vary at different maintenance categories, appropriate "work time" figures will be shown for each category. The number of taskhours specified by the "work time" figure represents the average time required to restore an item (assembly, subassembly, component, module, end item or system) to a serviceable condition under typical field operating conditions. This time includes preparation time, troubleshooting time, and quality assurance/quality control time in addition to the time required to perform the specific tasks identified for the maintenance functions authorized in the maintenance allocation chart. Subcolumn of column 4 are as follows:

- C - Operator/Crew
- O - Organizational

- F - Direct Support
- H - General Support
- D - Depot

e. *Column 5, Tools and Equipment.* Column 5 specifies by code those common tool sets (not individual tools) and special tools, test, and support equipment required to perform the designated function.

f. *Column 6, Remarks.* Column 6 contains an alphabetic code which leads to the remark in section IV, Remarks, which is pertinent to the item opposite the particular code.

B-4. Tool and Test Equipment Requirements (Sec III)

a. *Tool or Test Equipment Reference Code.* The number in this column coincide with the numbers used in the tools and equipment column of the MAC. The numbers indicate the applicable tool or test equipment for the maintenance functions.

b. *Maintenance Category.* The codes in this column indicate the maintenance category allocated the tool or test equipment

c. *Nomenclature.* This column lists the noun name and nomenclature of the tools and test equipment required to perform the maintenance functions.

d. *National/NATO Stock Number.* This column lists the National/NATO stock number of the specific tool or test equipment.

e. *Tool Number.* This column lists the manufacturer's part number of the tool followed by the Federal Supply Code for manufacturers (5-digit) in parentheses.

B-5. Remarks (Sec IV)

a. *Reference Code.* This code refers to the appropriate item in section II, column 6.

b. *Remarks.* This column provides the required explanatory information necessary to clarify items appearing in section II.

(Next printed page B-3)

**SECTION II. MAINTENANCE ALLOCATION CHART
FOR
AUDIO LEVEL METER TA-885/U**

(1) GROUP NUMBER	(2) COMPONENT ASSEMBLY	(3) MAINTENANCE FUNCTION	(4) MAINTENANCE CATEGORY					(5) TOOLS AND EQUIPMENT	(6) REMARKS
			C	O	F	H	D		
00	AUDIO LEVEL METER TA-885/U (HP 3555B)	Inspect Test Service Repair Overhaul		0.5		0.5 0.8 1.2	2.0	7 1 thru 7 1 thru 7 1 thru 7 1 thru 7	

**SECTION III. TOOL AND TEST EQUIPMENT REQUIREMENTS
FOR
AUDIO LEVEL METER TA-885/U**

TOOL OR TEST EQUIPMENT REF CODE	MAINTENANCE CATEGORY	NOMENCLATURE	NATIONAL/ NATO STOCK NUMBER	TOOL NUMBER
1	H,D	OSCILLATOR SG-1128/U, HP #654A	6625-00-450-7590	
2	H,D	OSCILLATOR AN/URM-127	6625-00-783-5965	
3	H,D	TRANSFORMER (LINE MATCHING) MX-8385/U	6625-00-567-5837	
4	H,D	MULTIMETER AN/USM-451	6625-01-060-6804	
5	H,D	AMPLIFIER HP-467A	6625-00-458-2480	
6	H,D	VOLTMETER, ELECTRONIC ME-30 E/U	6625-00-643-1670	
7	O	COMMON TOOLS NECESSARY TO THE PERFORMANCE OF THIS MAINTENANCE FUNCTION ARE AVAILABLE TO MAINTENANCE PERSONNEL FOR THE MAINTENANCE CATEGORY LISTED.		



TRANSMISSION AND NOISE MEASURING SET

This manual backdating sheet makes this manual applicable to earlier instruments. Instrument-component values that differ from those in the manual, yet are not listed in the backdating sheet, should be replaced using the part number given in the manual.

Instrument Serial Prefix	Make Manual Changes
916-00500 and below	1 thru 7
916-00509 and below	2 thru 7
953-00544 and below	3 thru 7
953-00825 and below	4 thru 7
0992A01395 and below	5 thru 7
0992A03536 and below	6, 7

Instrument Serial Prefix	Make Manual Changes
0992A03537 and below	7

Change No. 1

In instruments with S/N 916-00500 and below CR1 and C2 in the power supply were located as shown in the following figure:

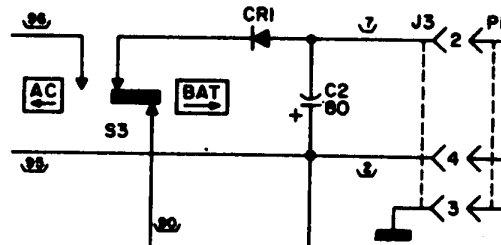

Change No. 2

Table 6-1 and figure 7-3, change:
 A2C8 to 33pF, part no. 0160-2150
 A2C9 to 320pF, part no. 0140-0226
 A2C10 to 39pF, part no. 01400175
 A2C11 to 51 pF, part no. 0160-2201

Change No. 3

Figure 7-4, change the pin connections as follows: 7 to 6, 13 to 12, 16 to 15, 15 to 13. Instruments with serial numbers 953)00544 and below had a 03555-66506 Revision A board in them. This board is not interchangeable with the Revision B board. The above pin connections are for the Revision A board.

Change No. 4

Delete S6 in figure 7-5 and in Table 6-1. Earlier instruments did not have this switch. See the following figure for earlier instruments.

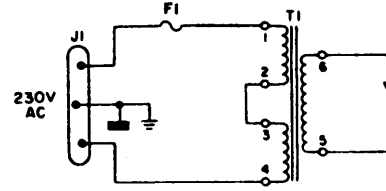
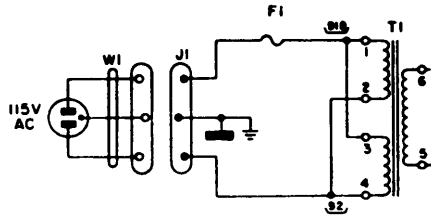

Change part no. of the case assembly to 03555-04505.

Change cover part no. to 03555-04504.

Table 6-1.

Change the part no. of the power cord to 81 20-0249.

Change the part no. of the power connector J1 to 1251-0148.

Change No. 5

Table 6-1. Change to the following gray parts:

Cover, battery	00236-04104
Bracket, meter	00741-0 1209
Panel, front	03555-00203
Assy. cover	03555-64504
Assy. case	03555-64506
Knob, pushbutton	0370-0440

Change No. 6

Page 6-7. Change C2 to 0180-0110, 8 μ F

Delete CR2 -4 1901-0025.

Page 6-8. Change T1 part no. to 9100-1457.

Figure 7-5. Delete CR2 -4 from the Power Supply Rectifier.

Change No. 7

Page 6-7. Delete CR6, 1901-0040.

Figure 7-5. Delete CR6 across M1.

*U.S. GOVERNMENT PRINTING OFFICE: 1980-603-128/66

By Order of the Secretary of the Army:

E. C. MEYER
General, United States Army
Chief of Staff

Official:

J. C. PENNINGTON
Major General, United States Army
The Adjutant General

DISTRIBUTION:

Active Army:

HISA (Ft Monmouth) (21)
USAINSCOM (2)
COE (1)
TSG (1)
USAARENBD (1)
DARCOM (1)
TRADOC (2)
OS Maj Comd (4)
TECOM (2)
USACC (4)
MDW (1)
Armies (2)
Corps (2)
Svc Colleges (1)
USASIGS (5)
USAADS (2)
USAFAS (2)
USAIS (2)
USAFS (2)

USAICS (3)
MAAG (1)
USARMIS (1)
USAERDAA (1)
USAERDAW (1)
Ft Carson (5)
Ft Gillem (10)
Ft Gordon (10)
(CERCOM Ofc)
USA Dep (1)
Sig Sec USA Dep (1)
Army Dep (1) except
LBAD (14)
SAAD (30)
TOAD (14)
SHAD (3)
Units org under fol TOE:
29-207 (2)
29-610 (2)

ARNG: None

USAR: None

For explanation of abbreviations used, see AR 310-50.

RECOMMENDED CHANGES TO EQUIPMENT TECHNICAL PUBLICATIONS



THEN... JOT DOWN THE DOPE ABOUT IT ON THIS FORM, CAREFULLY TEAR IT OUT, FOLD IT AND DROP IT IN THE MAIL!

SOMETHING WRONG WITH THIS PUBLICATION?

FROM: (PRINT YOUR UNIT'S COMPLETE ADDRESS)

DATE SENT

PUBLICATION NUMBER

PUBLICATION DATE

PUBLICATION TITLE

BE EXACT... PIN-POINT WHERE IT IS

PAGE NO.	PARA-GRAPH	FIGURE NO.	TABLE NO.
----------	------------	------------	-----------

IN THIS SPACE TELL WHAT IS WRONG AND WHAT SHOULD BE DONE ABOUT IT:

TEAR ALONG PERFORATED LINE

PRINTED NAME, GRADE OR TITLE, AND TELEPHONE NUMBER

SIGN HERE:

DA FORM 2028-2
JUL 79

PREVIOUS EDITIONS ARE OBSOLETE.

P.S.—IF YOUR OUTFIT WANTS TO KNOW ABOUT YOUR RECOMMENDATION MAKE A CARBON COPY OF THIS AND GIVE IT TO YOUR HEADQUARTERS.

